



ARMAX

SS123HP

SAFARI ARMAX SNORKEL

TOYOTA HILUX (Oct 2015 onwards)

2.4L & 2.8L Turbo Diesel D-4D (2GD-FTV & 1GD-FTV Engines),
4.0L V6 (1GR-FE Engine)

NOTE: WIDE BODY MODELS ONLY



01/09/2017

Parts List

ITEM	PART NO.	DESCRIPTION	QTY
1	322-133-600	BODY - SNORKEL (SS123HP)	1
2	000-135-960	4" AIR RAM ASSEMBLY	1
3	322-032-600	BRACKET - UPPER MOUNTING	1
4	000-002-100	BOLT - HEX - 6mm x 1.0 x 14mm (SEMS) - S/S	2
5	000-951-300	SCREW - S/T - 4.2mm x 16mm - S/S	3
6	000-960	INSERT - PLASTIC	3
7	000-110	STUD - 8mm x 1.25 x 25mm - S/S	6
8	000-311-300	WASHER - BODY - 8mm x 30mm - S/S	6
9	000-205-300	NUT - NYLOC - 8mm x 1.25mm - S/S	6
10	322-024-600	HOSE - AIR ENTRY	1
11	000-910	CLAMP - HOSE - 90/110mm - S/S	1
12	000-1911	CLAMP - HOSE - 100/120mm - S/S	1
13	322-967-600	PLATE - INNER GUARD SUPPORT - S/S	1
14	000-1027-300	BOLT - B/H CAP SCREW 10mm x 1.5 x 20mm - S/S	1
15	000-303-300	WASHER - FLAT - 10mm x 20mm x 2.0mm - S/S	2
16	000-206-300	NUT - NYLOC - 10mm x 1.5mm - S/S	1

17	000-1020-300	BOLT - B/H CAP SCREW 5mm x 12mm - S/S	4
18	000-320-350	WASHER - BODY - 5mm x 15mm - S/S	8
19	000-221-300	NUT - NYLOC - 5mm x 0.8mm - S/S	4
20	000-1931/B	CLAMP - HOSE - SIZE 64 (BLACK)	1
21	322-017-600	TEMPLATE - GUARD PANEL	1



SS123HP

SAFARI ARMAX SNORKEL

TOYOTA HILUX (Oct 2015 onwards)

2.4L & 2.8L Turbo Diesel D-4D (2GD-FTV & 1GD-FTV Engines),
4.0L V6 (1GR-FE Engine)

NOTE: WIDE BODY MODELS ONLY

Installation Guide

Fitment to:

- Right Hand Side

Fitting Time:

- 180min

Special Tools:

- Body Saw (reciprocating)
- Step Drill
- 90 degree drill
- Die Grinder
- 5.0mm & 5.5mm Drill Bits
- Sikaflex 227 Adhesive Sealant
- Loctite 243 (thread lock)
- Masking Tape
- Touch-up paint

Prior to commencing the installation, it is the installer's responsibility to verify that all components and particularly the template (Item 21) are correct.

1

Remove the following in accordance with the factory service manual:

- Air Cleaner assembly
- RHS Mud Flap
- RHS Guard Liner
- RH Guard upper plastic Trim



2

Remove and discard

- Air intake ducting
- Air Deflector



3

Remove and discard the perforated section from the guard panel template (item 21) as shown.

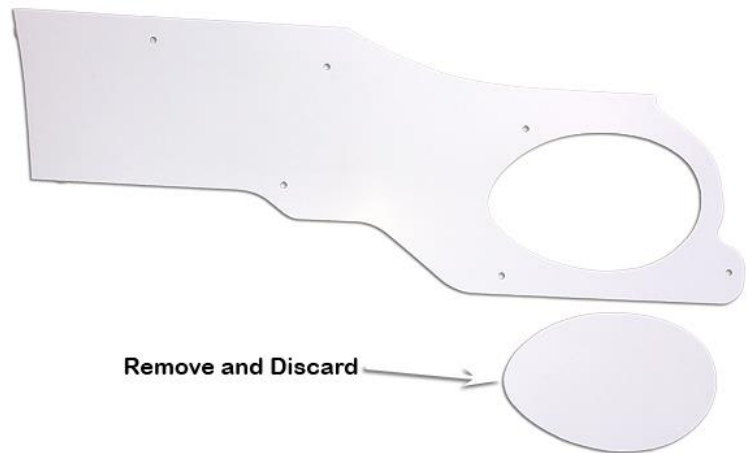

4

Align the guard panel template (Item 21) to the upper and rear edges of the right hand guard panel as shown.

Tape the template to the guard panel with masking tape.

Mark all hole positions and the cut-out section with a felt tip pen.

Remove the template.

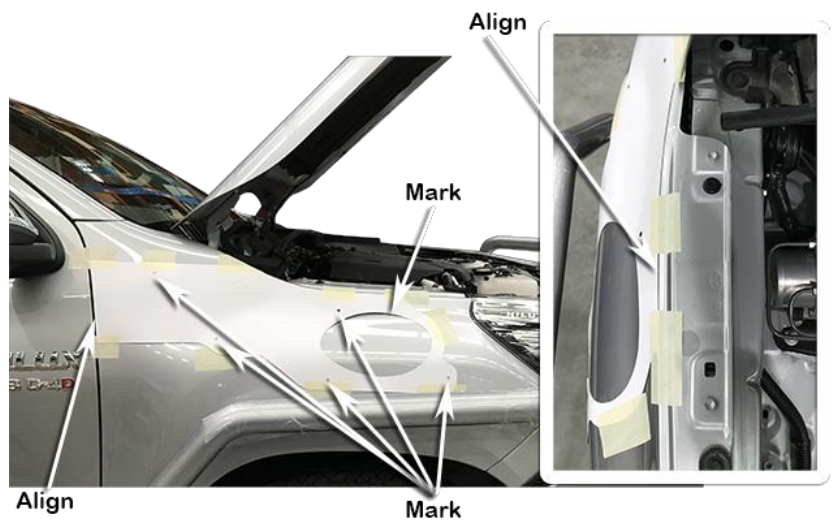

Drill a pilot hole for each of the marked positions.

Use a step drill to drill the 6 mounting holes to 16mm diameter.

Drill 2 or 3, 10mm diameter holes in the cut-out section for a start/stop point for the body saw, using the body saw cut the main hole in the guard panel as marked from the template cut-out in step 4.

Deburr and paint holes.

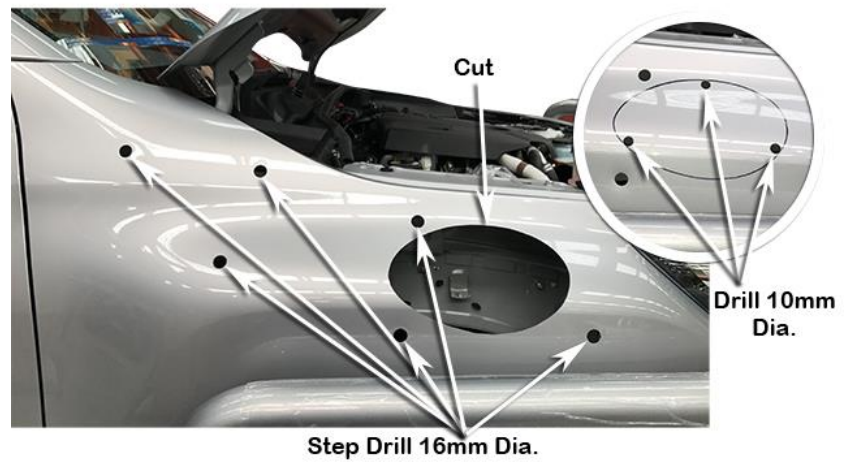

Install the upper mounting bracket (Item 3) to the snorkel body (Item 1) with hex bolts (Item 4).

Apply Loctite 243 to each of the stainless steel mounting studs (Item 7) and install the studs finger tight into the snorkel body (Item 1) mounting inserts as shown.

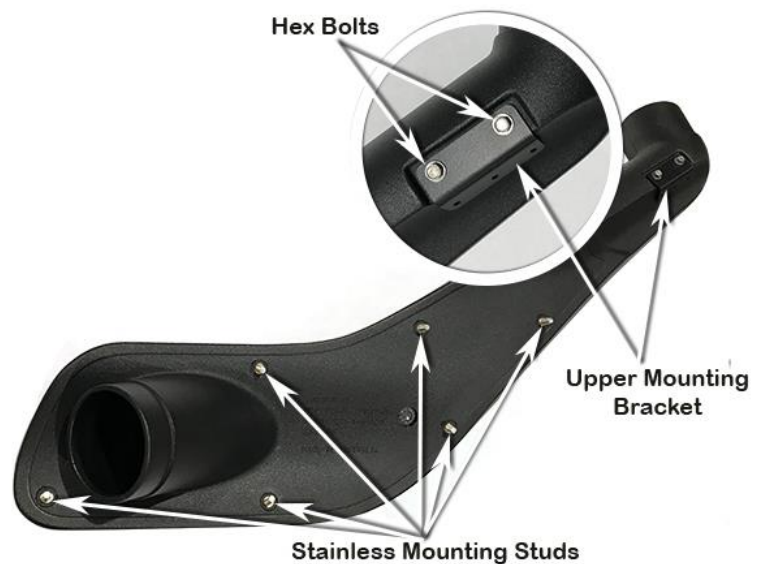

Place a strip of masking tape along the A-pillar panel.

Carefully install the snorkel body (Item 1) to the guard panel.

With the snorkel body correctly positioned on the vehicle, accurately mark the position of the upper mounting bracket (Item 3) onto the masking tape.

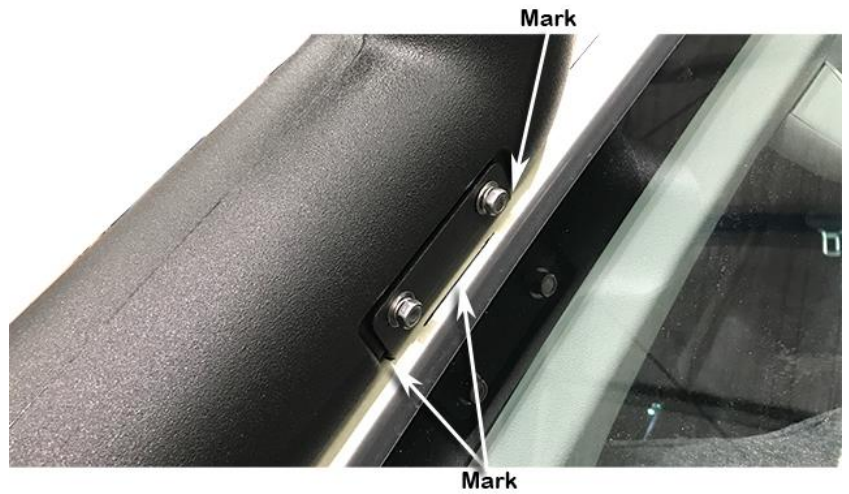

Remove the snorkel body (Item 1) from the vehicle and remove the upper mounting bracket (Item 3) from the snorkel body.

Position the upper mounting bracket (Item 3) onto the A-pillar and align the bracket with the marked bracket outline. Mark the three mounting hole positions with a felt tip pen.

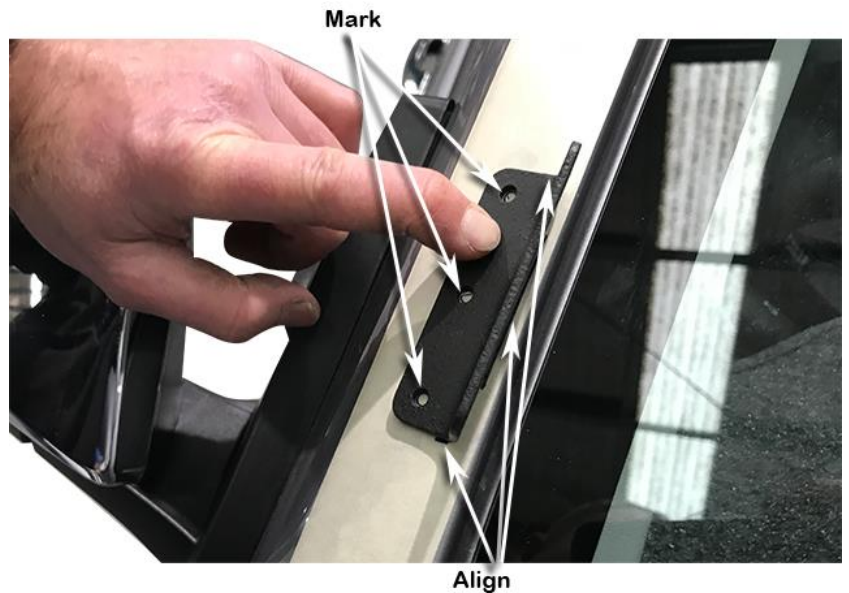

Drill a pilot hole at each of the three marked hole positions. Drill each hole position to 8mm diameter with a step drill or 8mm drill bit.

Deburr and paint holes.



Install the plastic inserts (Item 6) into the 8mm diameter holes in the A-pillar.

Secure the upper mounting bracket (Item 3) to the A-pillar with three self-tapping screws (Item 5).

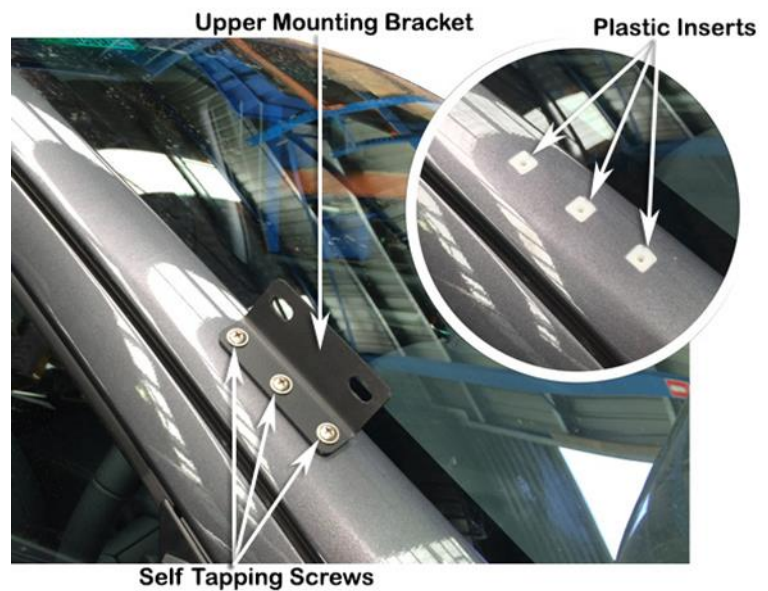

11

Install the inner guard support plate (item 13) to the wheel arch side of the inner guard panel, align the support plate to the 10mm hole in the inner guard panel and the edge of the reinforcement panel as shown.

Install the 10mm button head bolt with the 10mm flat washer installed (item's 14 & 15) through the hole and fasten with 10mm flat washer and 10mm nyloc nut (item's 15 & 16), place a strip of masking tape to hold the plate to the inner guard panel.



12

With the inner guard support plate correctly aligned, drill the two lower and upper rear mounting hole positions through the support plate (item 13) using the 90 degree drill and 5.0mm drill bit.

Mark the cut-out section onto the inner guard panel with a felt tip pen.

Remove the support plate.



13

Install the support plate to the engine compartment side of the inner guard panel, secure to the inner guard with the 10mm button head bolt, 10mm flat washers and 10mm nyloc nut, install two 5mm button head bolts (item 17), 5mm body washers (item 18) and 5mm nyloc nuts (item 19), with the support plate correctly aligned, mark the cut-out section with a felt tip pen onto the inner guard panel.

Using the 5mm drill bit, drill the top support plate mounting hole.

Remove the support plate.

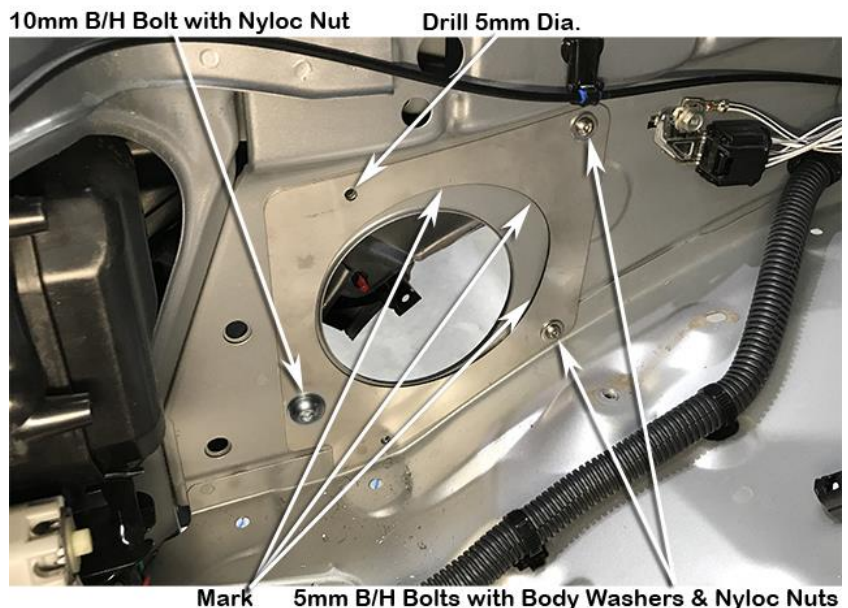

Drill 1 or 2, 10mm holes in the marked cut-out section of the inner guard panel for a start/stop point for the body saw, using the body saw cut-out the marked section of the inner guard panel, cutting on the outside of the line.

Using a 5.5mm drill bit, drill the 4 mounting hole position to 5.5mm diameter.

Deburr and paint all holes and cut section of panel.

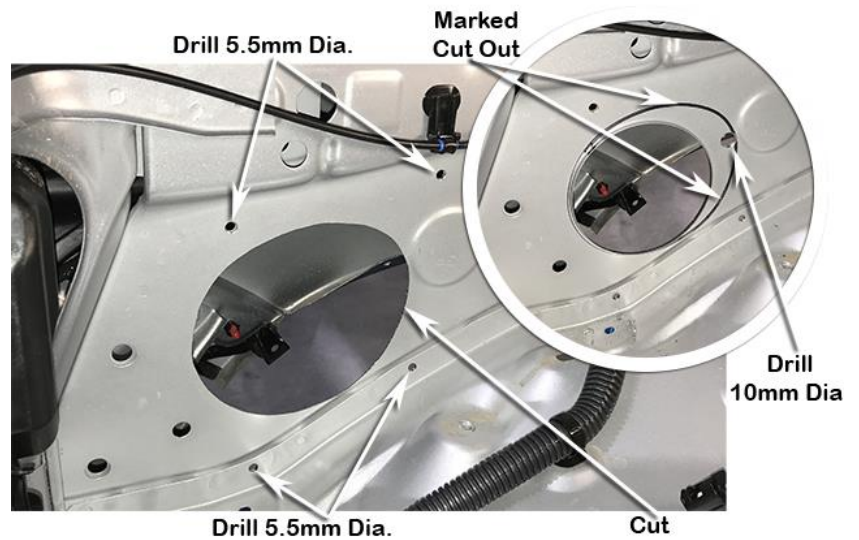

Apply a generous amount of Sikaflex sealant to the inner guard support plate (item 13), install the plate to the wheel arch side of the inner guard panel and secure with 5mm & 10mm button head bolts (item's 14 & 17), 5mm & 10mm washers (item's 15 & 18) and 5mm & 10mm nyloc nuts (item's 16 & 19), with all fasteners installed tighten and secure the support plate to the inner guard panel.

Clean-up any excess sealant to ensure a neat finish.

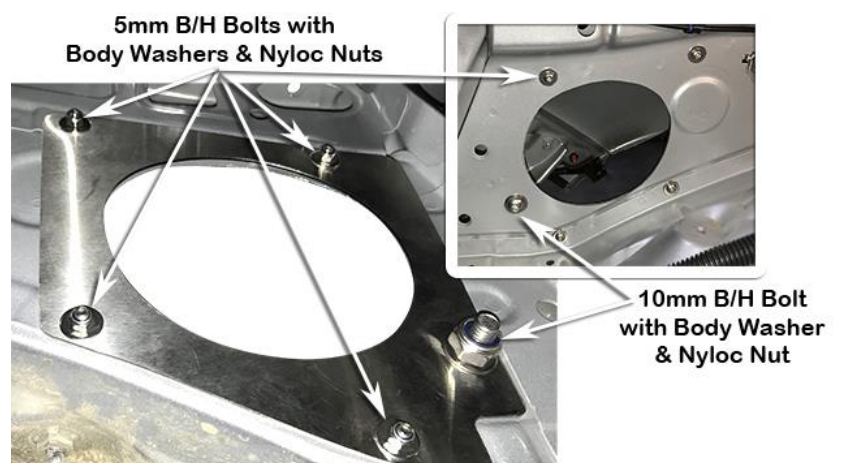

Carefully remove and discard the pre-spinner assembly from the air cleaner base inlet.



The pre-spinner chamber must be completely removed from the air cleaner base inlet, using the necessary tools carefully remove the chamber as shown.

Step 1; Using a die grinder with a cut-off disc, remove as much of the internal tube as possible (60mm approximately), care must be taken when using the cut-off disc not to cut through the outer and inner walls of the air cleaner base.



Step 2; Using the body saw cut away as much of the end section of the chamber as possible.

Step 3; Using a die grinder with a suitable burr, carefully remove the end section of the chamber.

Step 4; Use a file to neatly remove the remaining material from the end of the chamber.



Remove End Section of Pre Spinner Chamber

18

INSTALLER OPTION :

The air cleaner base contains a drain valve and drain hole as shown. The drain valve and drain hole can permit water to enter the air intake.

Safari advises that the drain valve and drain hole should be sealed to ensure a watertight installation.

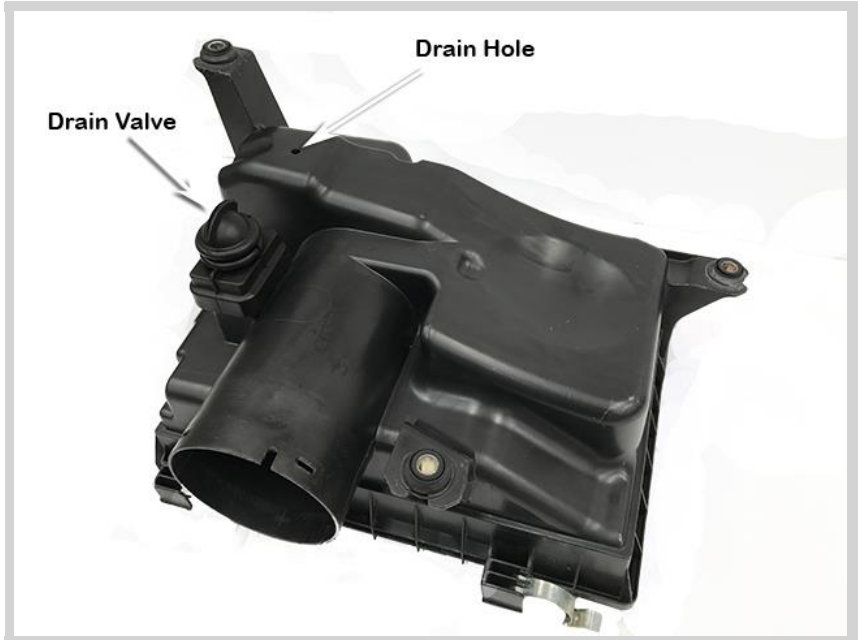

19

Install the air entry hose (item 10) through the hole in the inner guard panel, loosely install a 90/110mm hose clamp (item 11) onto the air entry hose.

Re-install the air cleaner base, guiding the air cleaner base inlet into the air entry hose, fasten the air cleaner base using standard mounting bolts.



20

Loosely install a 100/120mm hose clamp (item 12) onto the air entry hose inlet and align the air entry hose (item 10) to the main hole in the guard panel.

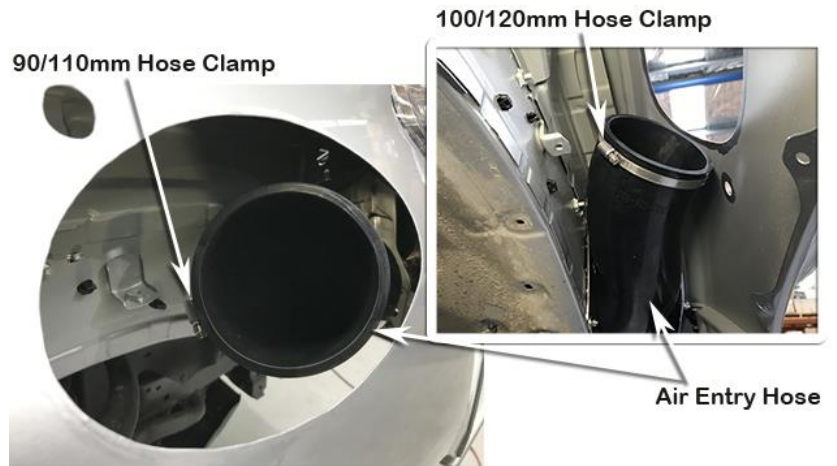

Carefully install the snorkel body (Item 1) to the guard panel, guiding the snorkel body outlet snout into the air entry hose (item 10), align the snorkel body to guard panel and upper mounting bracket.

When correctly aligned, fasten the snorkel body to the guard panel with body washers (Item 8) and nyloc nuts (Item 9).

Fasten the snorkel body to the upper mounting bracket with hex bolts (Item 4).



Align the air entry hose for best fitment (*Ensure the air entry hose is installed hard up against the shoulder of the snorkel body outlet*), correctly position the hose clamps at either end of the air entry hose and tighten the hose clamps.

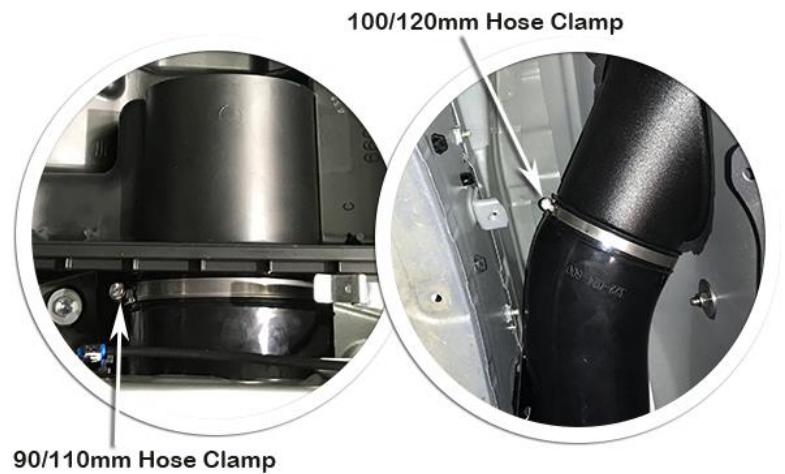

23

Loosely install the black hose clamp (Item 20) over the base of the air ram assembly (Item 2).

Install the air ram assembly onto the snorkel body.

Align the air ram assembly and tighten the black hose clamp (Item 20).



24

Install the guard liner, mud flap, air cleaner element, air cleaner lid, reconnect sensor wiring, install the RH guard upper plastic trim and any other items that may have been removed during the snorkel installation process.

25

N.B: It is the installer's responsibility to ensure that all connections are water tight.