

INSTALLATION GUIDE



IRP005

TO SUIT TOYOTA 80, 100, 105 SERIES
TO SUIT NISSAN GU PATROL*
TO SUIT NISSAN NAVARA D40, NP300



- Ironman 4x4 Recovery Points fit to the chassis
- It will take about 20 mins to install on Toyota or Nissan Patrol (see page 2)
- For Nissan Navara, bull bar or front bumper will be need to be removed to install Ironman 4x4 recovery points (see page 3)
- Below is a list of required tools for installing your Ironman 4x4 Recovery Points:
 - 17 and 19mm socket
 - 19mm spanner
 - Torque wrench*Assorted other tools will be required to remove bull bar or front bumper on Nissan Navara*

*** Left and Right Hand recovery points will need to swap sides**

IMPORTANT: Recovery Point installations should only be done by a qualified person and it's the responsibility of this person to ensure correct fitment.

1. Before installation check recovery point application is compatible with your vehicle.

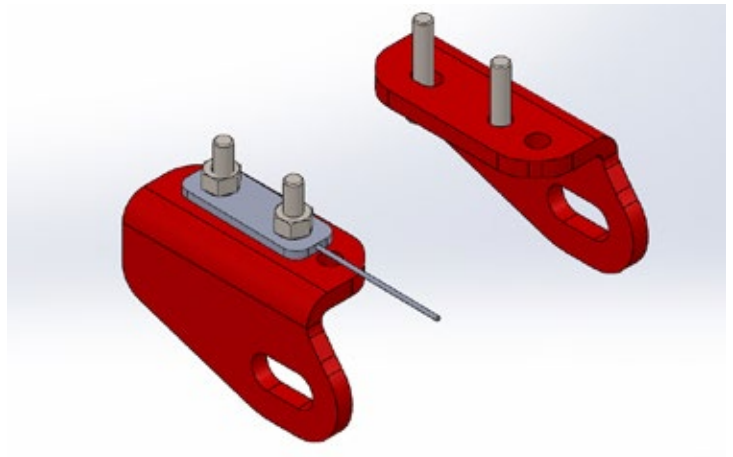

**Toyota 80, 100, 105 Series
Nissan GU Patrol**

-
2. On passenger side, lift recovery point into position.
-
3. Using M14 bolts and washers (supplied), insert through hole into captive chassis nuts.
-
4. On drivers side, slide 60mm nut plate (supplied) into chassis rail and align with bolt holes in chassis.
-
5. Lift recovery point into position and secure using M14 bolts and washers (supplied). Attach to the chassis picking up the 60mm nut plate.



1. Before installation check recovery point application is compatible with your vehicle.

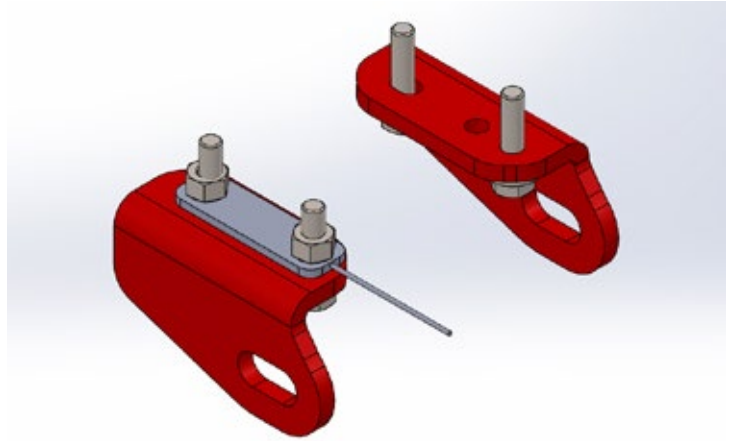

Nissan D40, NP300 Navara

2. Prior to installation, remove bull bar or front bumper.
3. On passenger side, lift recovery point into position.
3. Using M12 bolts and washers (supplied), insert through hole into captive chassis nuts.
4. On drivers side, slide 90mm nut plate (supplied) into chassis rail and align with bolt holes in chassis.
5. Lift recovery point into position and secure using M12 bolts and washers (supplied). Attach to the chassis picking up the 90mm nut plate.

