




# FITTING INSTRUCTIONS

## LC76 WAGON - 930-A DRAWER MODULES



 Image for illustration purposes only.



[MSA4X4.COM.AU](https://www.msa4x4.com.au) | GEAR FOR LIFE

# CONTENTS

- 3** CONGRATULATIONS
- 4** GETTING STARTED:
- 5** IMPORTANT INFORMATION
- 6** FITTER'S QUICK INSTALLATION GUIDE
- 7** 3D DIAGRAM
- 8** FITTING DIAGRAM
- 9** BRACKET POSITIONS
- 10** DRAWER REMOVAL & REINSTALLATION
- 12** DRAWER MODULE PREP LEFT
- 13** DRAWER MODULE PREP RIGHT
- 14** DOUBLE DRAWER INSTALLATION
- 22** SINGLE DRAWER INSTALLATION LEFT
- 22** SINGLE DRAWER INSTALLATION RIGHT
- 23** DRAWER REMOVAL & INSTALLATION  
AFTER THE DRAWERS HAVE BEEN COMPLETELY INSTALLED
- 24** OPERATING INSTRUCTIONS
- 25** CARE & MAINTENANCE
- 26** WARRANTY





# CONGRATULATIONS ON YOUR PURCHASE OF A QUALITY MSA 4X4 DRAWER SYSTEM!

**Years of design, development and manufacturing knowledge goes into every  
MSA 4X4 product to ensure that our products are the very best they can be!**

Established in 2000, MSA 4X4 Accessories are the 4WD market leaders in quality Canvas products which include Certified ADR Compliant Canvas Seat Covers, Rear Wheel Bags, Rear Wheel Rubbish Bins, Vehicle Organisers and more. We pride ourselves on our innovative products which include the world first, revolutionary Fridge Dropside, the new patent pending Explorer Aluminium Storage Drawer System which delivers a whole new level of access to the drawer contents, the original Water Bra, fully adjustable air lumbar support systems, and an extensive range of 4x4 accessories that have stood the test of time. As testament to our innovative culture, we have been awarded 19 patents in Australia & Internationally across our range of products including innovations currently within the patent process. We are a growing team with a vast knowledge of what works and what doesn't work out in the real world and constantly strive to deliver the highest quality product to our customers. We treat every product design with fear of failure in mind, ensuring our products are always the very best they can be. All our products are designed to be as simple as possible to use and are supported by our MSA 4X4 Lifetime Guarantee.

**Our products are available through a network of over  
600 stockists Australia wide.**



## 4 **GETTING STARTED:** Here's what comes in the box



- 1 X** Drawer Module
- 2 X** Keys (located inside each drawer module)
- 1 X** Wing & Fit Kit box if ordered
- 1 X** Double Drawer Joining Kit if ordered
- 1 X** Crash Test Certificate

If anything is missing,  
please contact us via [msa4x4.com.au](http://msa4x4.com.au)



**GEAR FOR LIFE**

## **IMPORTANT INFORMATION**

It is important that you read and understand the below information before installing your new MSA 4X4 Explorer Aluminium Storage Drawer System.

## **MAINTAINING ADR COMPLIANCE OF YOUR DRAWER SYSTEM**

MSA 4X4 storage drawer systems have been legally crash tested and are supplied as an ADR compliant drawer module and fit kit system when the correct number fit kits for the EWFK-LC76-LEFT and EWFK-LC76-RIGHT are used for the installation and joining of the drawer modules. Failure to use a matching fit kit or components for the particular vehicle installation or the use of other components to install MSA 4X4 storage drawers may void the ADR compliance of the storage drawer system and/or the warranty.

## **UNDERSTANDING DIFFERENCES BETWEEN LEFT & RIGHT HAND SIDE MODULES:**

MSA 4X4 storage drawer systems are of a modular design, they do come in left and right hand side modules as the need for wires and switches must enter the frame from one side. The modules are clearly marked “left” and “right” on the packaging boxes. On the right (RHS) drawer, the wiring and the LED light switch is on the RHS of the drawer. On the left (LHS) drawer the wiring and switch is on the LHS of the drawer.

## **FRONT & REAR DEFINITIONS FOR FITTING INSTRUCTION PURPOSES:**

The “Front” is related to the front face of the drawer system, where the lock is located. (Towards the rear of the vehicle.) The “Rear” is related to the rear of the drawer system. (Towards the front of the vehicle.)

## TOYOTA LC76 WAGON

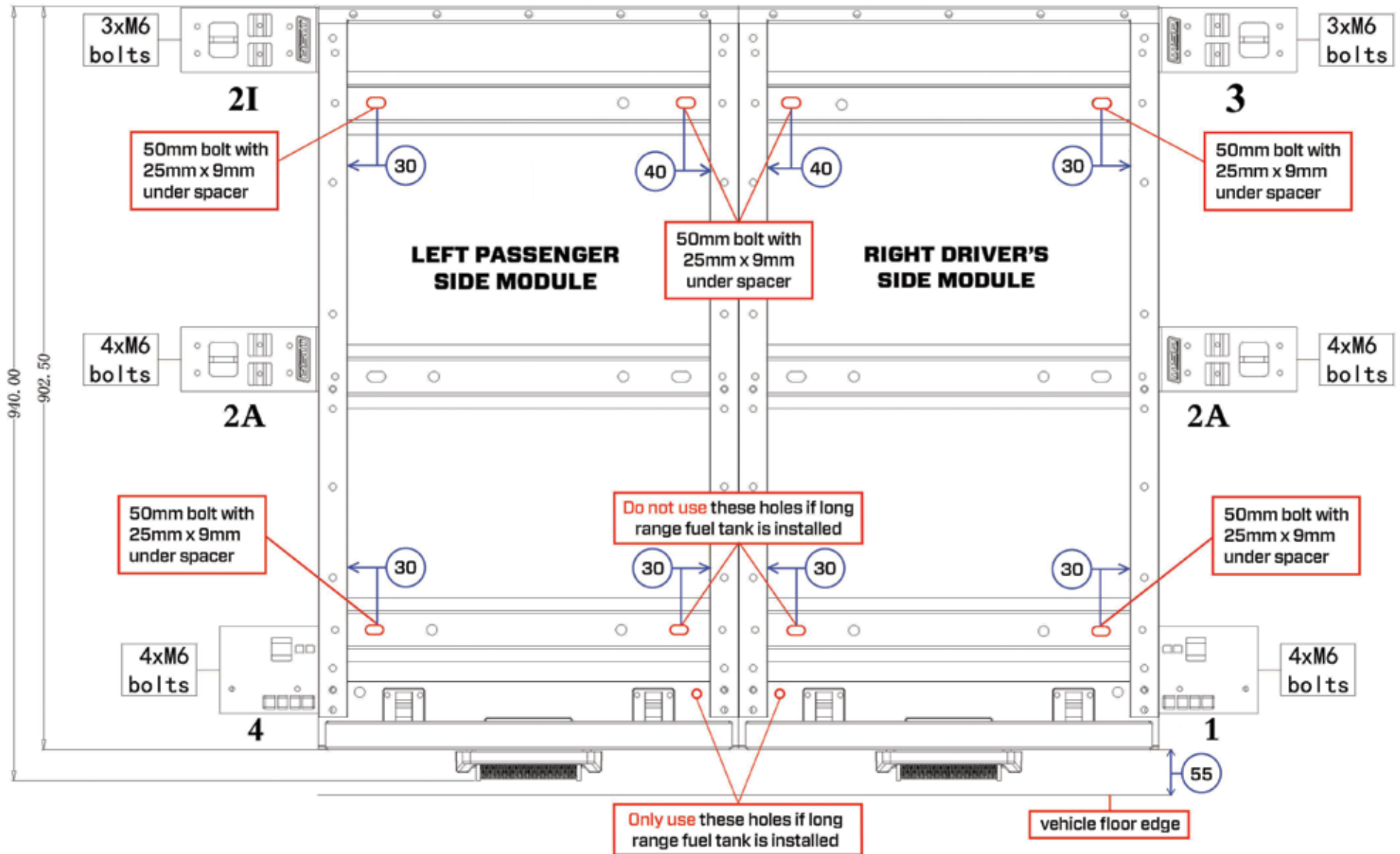
- 1** Prepare vehicle by removing vinyl floor liner or carpet and tie down points in tray.
- 2** Clean, vacuum and wipe down.
- 3** Remove drawer from frame if need - not necessary but easier for handling and installing the frames.
- 4** Prepare both drawers by installing any wing brackets and spacer blocks if needed  
- refer to fitting diagram on page 8 for more detailed instruction.
- 5** Place Right (driver's) side module in to vehicle.
- 6** Place Left (passenger's) side module into vehicle.
- 7** Join drawers with join kit bolts and tighten.
- 8** Centre the drawer frame in the car.
- 9** Drill holes in the floor through the cross channels and install bolts & washers as per the fitting diagram on page 8.
- 10** Do any wiring required for power supply to drawer frames.
- 11** Re-install drawers into frame.
- 12** Check that drawers function correctly.
- 13** Install the wing panels.
- 14** Install the large frame top panels.
- 15** Install top panel and front trim and install wing panel trims.

# EXPLORER ALUMINIUM DRAWER SYSTEM

7



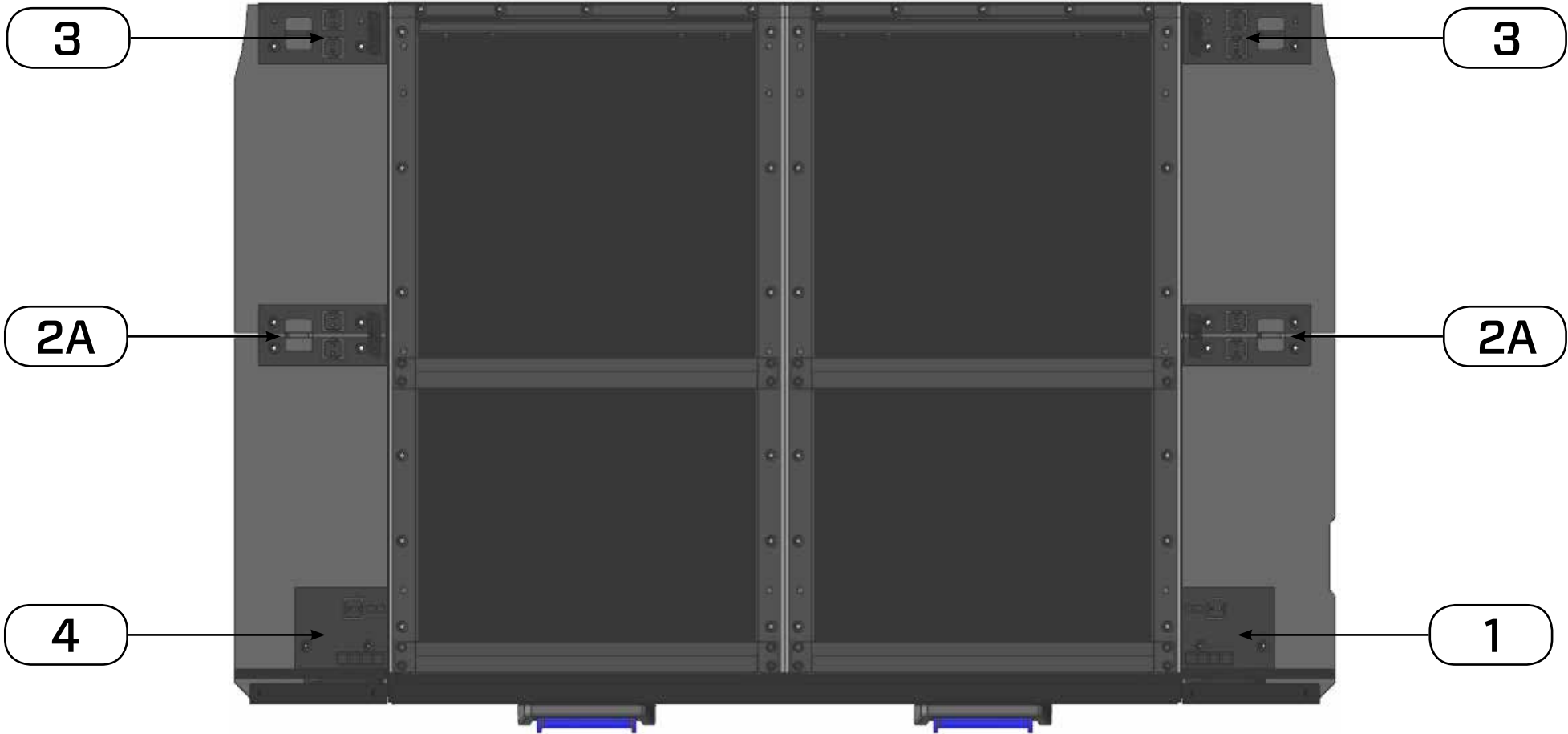
# LC76 WAGON FITTING DIAGRAM



**FRONT OF DRAWER (BACK OF CAR)**



# BRACKET POSITIONS



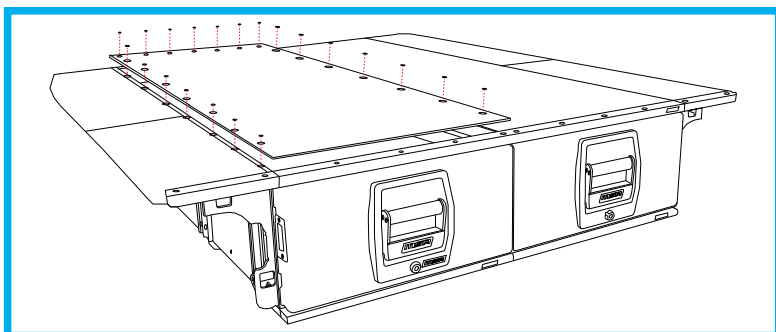
# DRAWER REMOVAL & REINSTALLATION

**PLEASE FOLLOW THESE DRAWER MODULE PREPARATION INSTRUCTIONS TO ENSURE THAT YOUR NEW EXPLORER ALUMINIUM STORAGE DRAWER SYSTEM IS INSTALLED CORRECTLY.**

- 1** **Note:** Drawer preparation requires the drawer to be open to full extension so a long flat surface is required for this prep.
- 2** **Tip:** A cordless drill, hex bit to 1/4 and 3/8 drive socket adapters, a set of 1/4 and 3/8 drive hex head bits and a set of metric spanners are recommended for installation ease.
- 3** Remove one drawer module from its packaging and place on a flat surface – a 2.4 metre flat bench is recommended.
- 4** Remove the carpeted top panel by removing the 21 x M6 countersunk Allen head bolts (this is quickest with a cordless drill, 1/4 drive adapter and 1/4 drive 4mm hex head socket bit) set the panel aside. **(FIG. 1 & 1a)**

## DRAWER REMOVAL

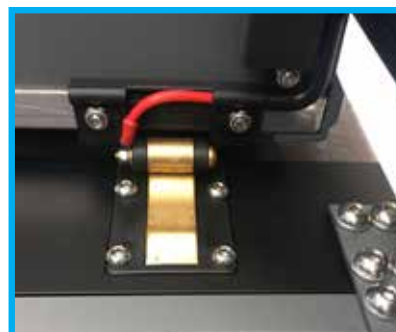
- 5** The drawers can be installed with or without removing the drawers from the frame. It is easy and quick to remove the drawer from the frame which makes it easier to handle and install.
- 6** If you choose to remove the drawer, start by fully extending the drawer so that the brass electrical contacts and stay open device are completely engaged. **(FIG. 2)**
- 7** Support the end of the open drawer near the lock with a corner piece of packing from the box. **(FIG. 3)**



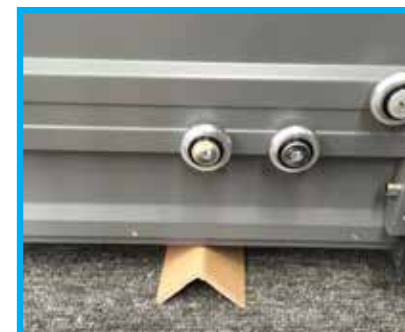
**FIG. 1**



**FIG. 1a**



**FIG. 2**



**FIG. 3**

- 8** You can now see the internal workings of the drawer system. Remove the two black injection moulded guide stopper blocks by removing the 4 x 4mm allen head bolts in each block. This is best done with a small hex bit attached to a flexible drive shaft and a cordless drill. **(FIG. 4 & 4a)**
- 9** Repeat this on the opposite side of the drawer.
- 10** Once both blocks are removed, the middle aluminium extrusions on each side of the drawer can be carefully slid forward until the drawer is clear of the frame. **(FIG. 5 & 5a)**
- 11** The drawer can now be moved away, taking care not to allow the loose centre extrusion to run out.
- 12** Install the wing brackets on the frame starting with number 2 on the next page.



**FIG. 4**



**FIG. 4a**



**FIG. 5**



**FIG. 5a**

# 12 DRAWER MODULE PREP LEFT

## LEFT SIDE (PASSENGER) DRAWER PREPARATION

- 1** If the drawer is going to be left in during installation, open the drawer to its full extension by pulling on the blue lock handle. Ensure drawer is pulled out to full 100% extension and the stay open devices are engaged in the base of the frame. To keep drawer level while installing wing brackets, place a small piece of angular packing cardboard under the lock end of the drawer for support. **(FIG. 6)**
- 2** Starting with bracket number **(4)** install at the front of the LHS of the frame through the pre-drilled holes using 4 x M6 hex head bolts, use a 10mm socket and extension bar to install these bolts, flat and spring washers. Install the bolts from the inside of the frame out into the bracket. Leave all bolts loosely installed until all 4 are started, then align the bracket parallel with the front of the drawer frame and tighten all four bolts with the 10mm socket. **(FIG. 7 & 7a)**
- 3** Install bracket number **(2A)** in the middle pre-drilled holes of the LHS of the drawer frame following the procedure for bracket 1. **(FIG. 8)**



**FIG. 6**



**FIG. 7**



**FIG. 7a**

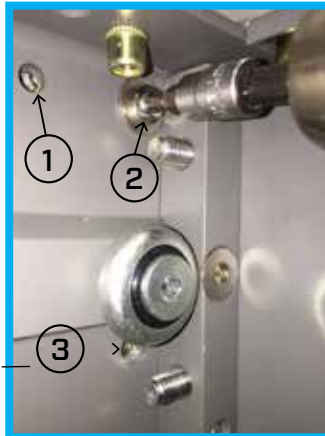


**FIG. 8**

- 4** Install bracket number ③ to the rear LHS of the frame by first removing the top two M8 high tensile bolts from the top of the frame. **(FIG. 9)**  
**PLEASE NOTE:** only three (3) bolts are to be used in this bracket, the top two and one lower at the rear of the frame. **(FIG. 9a)** Use the 3 x M6 allen head bolts and washers. Following the same tightening procedure as brackets 1 and 2 to fasten the bracket. **(FIG. 9b)**
- 5** Install the 2 x C clips onto the underside of the wing panels and then install the side wing panels on both sides of the drawers. To assist with the frame alignment in tray, centralise the drawer frame in the vehicle by measuring to a similar reference point from both sides of the vehicle tray. **(FIG. 10)**



**FIG. 9**



**FIG. 9a**



**FIG. 9b**



**FIG. 10**

# 14 DRAWER MODULE PREP RIGHT

## RIGHT SIDE (DRIVER) DRAWER PREPARATION

- 1** If the drawer is going to be left in during installation, open the drawer to its full extension by pulling on the blue lock handle. Ensure drawer is pulled out to full 100% extension and the stay open devices are engaged in the base of the frame. To keep drawer level while installing wing brackets, place a small piece of angular packing cardboard under the lock end of the drawer for support. **(FIG. 11)**
- 2** Starting with bracket number ① install at the front of the RHS of the frame through the pre-drilled holes using 4 x M6 hex head bolts, use a 10mm socket and extension bar to install these bolts, flat and spring washers. Install the bolts from the inside of the frame out into the bracket. Leave all bolts loosely installed until all 4 are started, then align the bracket parallel with the front of the drawer frame and tighten all four bolts with the 10mm socket. **(FIG. 12 & 12a)**
- 3** Install bracket number ②A in the middle pre-drilled holes of the RHS of the drawer frame following the procedure for bracket 1. **(FIG. 13)**



FIG. 11



FIG. 12



FIG. 12a



FIG. 13

- 4** Install bracket number ③ to the rear RHS of the frame by first removing the top two M8 high tensile allen heads from the top of the frame. (FIG. 14)

**PLEASE NOTE:** only three (3) bolts are to be used in this bracket, the top two and one lower at the rear of the frame. (FIG. 14a) Use the 3 x M6 allen head bolts and washers. Following the same tightening procedure as brackets 1 and 2 to fasten the bracket. (FIG. 14b)

- 5** Install the 2 x C clips onto the underside of the wing panels and then install the side wing panels on both sides of the drawers. To assist with the frame alignment in tray, centralise the drawer frame in the vehicle by measuring to a similar reference point from both sides of the vehicle tray. (FIG. 15)



FIG. 14

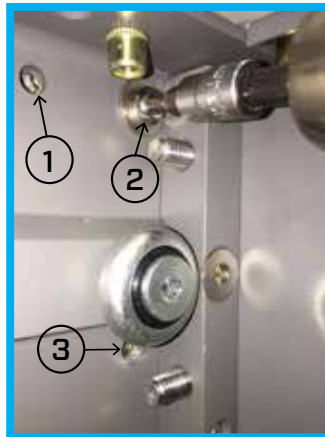


FIG. 14a



FIG. 14b



FIG. 15

# DOUBLE DRAWER INSTALLATION

## DOUBLE DRAWER INSTALLATION

- 1** Remove any carpet or floor liner from the rear of the vehicle. **(FIG. 16)**
- 2** With assistance, carefully place the RHS drawer module into the vehicle and push to RHS.
- 3** Again with assistance, now place the LHS drawer module into the vehicle.
- 4** Now the drawers need to be joined.
- 5** Open both drawers if the drawers are still in the frame, taking care to support under the front end of the drawer.
- 6** There are 8 x M8 Allen Head bolts and nyloc nuts used to join the drawer frames. Starting at the rear of the frame at the top, place an M8 bolt through the top hole that is aligned in the frame for joining. It is easiest to use a cordless drill with adaptor and an M5 hex head socket bit and a 13mm spanner. Place the M8 nyloc nut on the other side of the frame. Leave the bolt loose. **(FIG. 17)**
- 7** Working forwards install all 4 of the top row of M8 bolts in the same manner. Leave the bolts loose.
- 8** Working from the front back now install the bottom 4 x M8 bolts and nuts. Leave the bolts loose.
- 9** Starting at the rear top of the frame, ensure frame tops are perfectly level and tighten the rear top bolt.
- 10** Repeat the same on the front top bolt ensuring both frames are perfectly level then tighten the nut.
- 11** Now work front to back on the lower row of 4 bolts and tighten all. Then tighten the remaining top 2 bolts on the top row.
- 12** The drawers can now be centralised in the car by measuring both sides of the frame to similar places of the vehicle tray. **(FIG. 18 & 18a)**



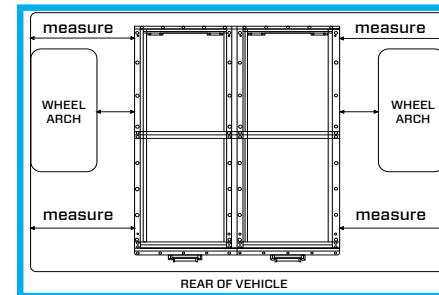
**FIG. 16**



**FIG. 17**



**FIG. 18**

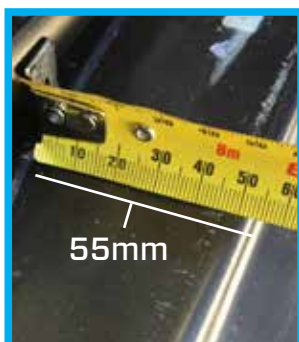


**FIG. 18a**



## PLEASE FOLLOW THESE DRAWER MODULE PREPARATION INSTRUCTIONS TO ENSURE THAT YOUR NEW EXPLORER ALUMINIUM STORAGE DRAWER SYSTEM IS INSTALLED CORRECTLY.

- 13** If the vehicle already has a long range fuel tank installed, there are two rivet nuts that need to be installed now. These two bolts are not for ADR compliant mounting, they are solely to prevent vibration of the drawer system over extremely rough roads. *If the vehicle has no long range tank installed, skip to page 17.*
- 14** Ensure that the front base frame is 55mm back from the edge of the vehicle floor and the drawer frame is central in the vehicle. Now mark the floor through the two inside 13mm holes that are in the black anodised base cross frame - these holes are 15mm in from the side of the frame. **(FIG. 19, 19a & 19b)**  
PLEASE NOTE: There is only one hole to be marked and drilled on the inside of each drawer frame.  
PLEASE NOTE: Do NOT use the other two mounting bolts further back in the front lower cross channel if there is a long range tank installed. Only the front two M6 bolts are to be used on the inside of the frames.
- 15** After the holes are marked, slide the drawer frame back slightly to expose the marks. Check for any wiring or accessories under the vehicle floor that may have been installed aftermarket. Drill a pilot hole with a 4mm drill bit, taking care to go only several millimetres through the floor. Now drill a 9mm hole to give tight clearance for the rivet nuts and then remove all shavings. Now paint the holes with some corrosion resistant paint and install both rivet nuts firmly. **(FIG. 20 & 20a)**



**FIG. 19**



**FIG. 19a**



**FIG. 19b**



**FIG. 20**



**FIG. 20a**

# DOUBLE DRAWER INSTALLATION

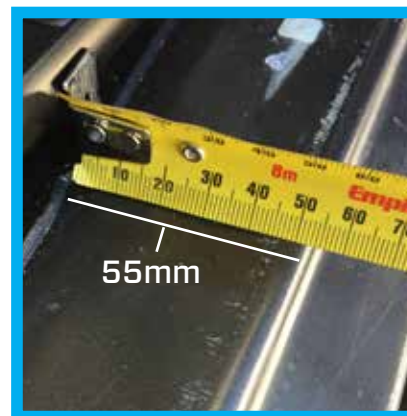
- 16** It is now time to place the frame back into its final position and do a check measure and install the two M6 x 40mm high tensile bolts, spring washer and flat washers through the frame. If the frame is central, these bolts can now be tightened using a 13mm spanner. **(FIG. 21 & 21a)**
- 17** The front of the drawer frame needs to be 55mm from the edge of the vehicle floor **(FIG. 22)** Refer to fitting diagram, pg. 8.
- 18** Install the 2 x C clips onto the underside of the wing panels and then install the side wing panels on both sides of the drawers. To assist with the frame alignment in tray, centralise the drawer frame in the vehicle by measuring to a similar reference point from both sides of the vehicle tray. **(FIG. 23)**
- 19** Now the M10 High Tensile fitting bolts, washers and blocks need to be installed.
- 20** Refer to the fitting diagram for hole measurements and exactly where to drill.
- 21** Before drilling through the tray, ensure there is nothing under the tray that could be damaged by drilling.
- 22** Taking care that the frame has not moved, mark the two outside rear holes using measurements from the fitting diagram
- NOTE:** These measurements are very specific, please be careful to follow them.



**FIG. 21**



**FIG. 21a**



**FIG. 22**



**FIG. 23**

- 23** It is now time to drill and bolt in the ADR compliant high tensile fitting assemblies. **(FIG. 24)**
- 24** Starting at the rear outsides of the frame and taking care that the frame has not moved, mark the two outside holes using measurements from the fitting diagram (page 8).  
NOTE: These measurements are very specific - please be careful to follow them.  
NOTE: The holes in the LC76 are drilled to the top of the floor corrugation. Drill a pilot hole using a 6mm drill bit through the tray, then follow with an 11mm drill bit to allow small clearance for the M10 bolt. The correct measurements are on the fitting diagram. Before drilling, check under the vehicle for any wiring or fuel line components. **(FIG. 25 & 25a)**
- 25** Remove drilling shavings by vacuum. **(FIG. 26)**
- 26** Using a small brush, paint the exposed metal of the drilled hole with a coat of paint to seal the metal and prevent any future corrosion. **(FIG. 27)**
- 27** Now install the bolt assemblies through the vehicle floor. **(FIG. 28)**



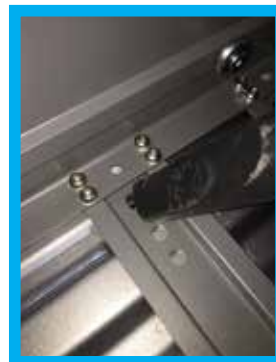
**FIG. 24**



**FIG. 25**



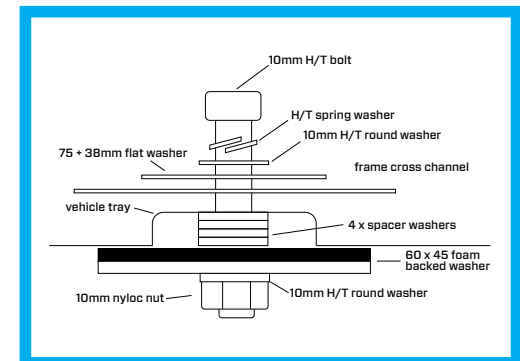
**FIG. 25a**



**FIG. 26**



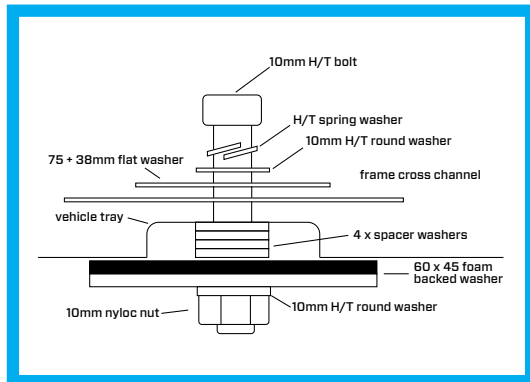
**FIG. 27**



**FIG. 28**

## 20 DOUBLE DRAWER INSTALLATION

- 28** With an assistant under the vehicle, install the under spacer washers, foam backed washers, round washer and nyloc nut as per the fitting bolt diagram. **(FIG. 29)**
- 29** Both bolts can now be tightened and torqued down to 30ftlb. **(FIG. 30, 30a & 30b)**
- 30** Repeat this process on the two rear inside mounting bolts and tighten.
- 31** Repeat this same process on the front outside two mounting bolts **(FIG. 31, 31a & 31b)**
- 32** If the vehicle has NO long range tank, repeat this process on the front centre two mounting bolts.



**FIG. 29**



**FIG. 30**



**FIG. 30a**



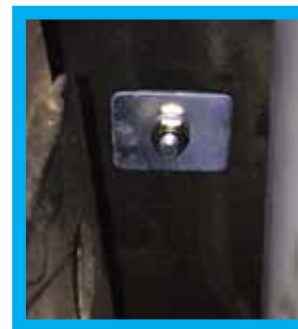
**FIG. 30b**



**FIG. 31**



**FIG. 31a**



**FIG. 31b**

## DRAWER RE-INSTALLATION

- 33** Now it is time to place the drawer back into the frame. First remove the fuse in the power supply to the drawers, as allowing the drawer frame to touch the main frame may blow the fuse. The best way to re-install the drawer into the frame is to rest the rollers at the rear base of the drawer into the end of the contacts on the base frame (**FIG. 32**) Then, hold the drawer horizontally parallel with the frame and then slide the two centre slide extrusions in to the roller bearings. (**FIG. 33 & 33a**)
- 34** After the centre extrusion has passed the middle roller bearings, the rear stopper blocks can be re-installed by placing the blocks in the aligning holes and tightening the 4 x M4 allen head bolts on each side. Please ensure all these 8 bolts have the spring washers installed. Do not over-tighten these bolts, just firm is enough (a 7-9 on the screw clutch setting on a cordless drill is a good guide). Repeat this process for the second drawer. (**FIG. 34**)
- 35** The fuse to the power supply can now be installed and the drawer LED strip lights check for function.
- 36** Now check that the power supply to the drawers is functional by opening the drawer to full extension so that the brass electrical contacts under the rear of the drawer frame, make contact. Check switch function. The LED Strip inside the drawer should light up. When pushing the drawer back in to the frame, the LED light will immediately switch off, to prevent the light from accidentally being left on.



**FIG. 32**



**FIG. 33**



**FIG. 33a**



**FIG. 34**

## 22 DOUBLE DRAWER INSTALLATION

**37** It is now a good time to wipe out the aluminium channels and give them a small spray of dry silicone lubricant. (This does not get done in the assembly process as it can attract grit from the installation process).

**38** Check that the drawers function correctly.

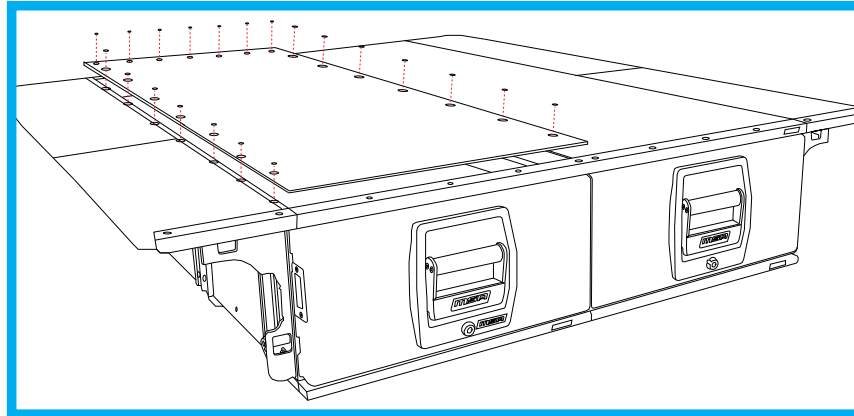
**39** The top panels can now be installed back onto the drawer frames. Place the panel in position and locate a bolt thread in each corner of the top. **(FIG. 35)**

Ensuring the 4 corner bolts have started, the remaining 17 x top hex head bolts can now be re-installed and tightened on each panel. These need only enough torque to pull the bolt head down to carpet level.

**Tip:** A very low 3 torque setting on a cordless drill is enough to tighten these bolts. **(FIG. 36)**

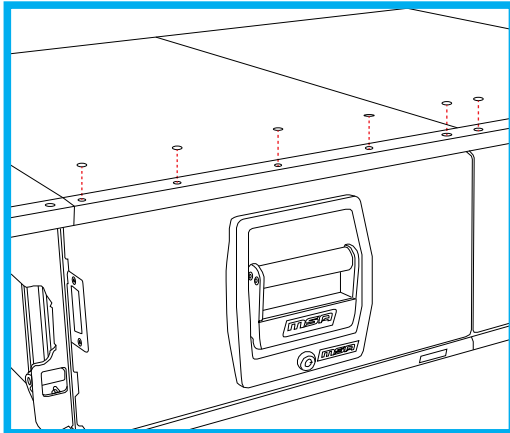


**FIG. 35**



**FIG. 36**

- 40** The double width top panel trim can now be installed. Push the trim firmly over the end of the double carpeted panels and centralise. Install the 10 x small stainless steel countersunk self-tap screws in the trim taking particular care to install them in a perfect vertical line. **(FIG. 37)**
- 41** The matching wing panel trims can now be installed using the same process. **(FIG. 38)**
- 42** The drawer System is now completely installed and ready for use. **(FIG. 39)**



**FIG. 37**



**FIG. 38**



**FIG. 39**

## **SINGLE DRAWER INSTALLATION LEFT**

Refer to double drawer installation **page 12**, ignoring any instructions referring to double drawers.

## **SINGLE DRAWER INSTALLATION RIGHT**

Refer to double drawer installation **page 13**, ignoring any instructions referring to double drawers.



**The MSA 4X4 Aluminium Drawer systems have been expertly designed to allow easy removal of the drawers from the frames if needed, without the need to remove the top decks of the system.**

- 1** Open the drawers to full extension and the stay open contacts engage at the underside rear of the drawer. (FIG. 40)  
Support the front of the drawer with some packing cardboard (FIG. 41)
- 2** Remove the fuse from the power supply to the drawers.
- 3** On either side of the sliding frame are two black injection moulded stopper blocks. These two blocks need to be removed to remove the drawer from the frame.
- 4** With a small screwdriver, pry the end cap away from the block, taking care not to mark the cap. Once removed, this will then give access to 4 x M4 allen head bolts with spring washers. (FIG. 42)
- 5** Remove these 4 bolts on each side with a hex bit and take care not to lose the washers. (FIG. 43 & 43a)
- 6** After the two blocks have been removed, the two middle pieces of the over extension slide can be slid back into the frame and out of the way. (FIG. 44)
- 7** The drawer is now completely free from the frame and just resting on the contacts. It can be lifted away from the frame.

**To re-install the drawers, follow the procedure in reverse, taking care to align the middle sliding extension carefully to not cause any marking.**

- 1** Sit the drawer rollers on the two contacts at the front of the frame. (FIG. 40)
- 2** Push the drawer three quarters of the way in to the middle slide extension while pulling the extensions out forward towards the front of the drawer frame. The stopper blocks can now be installed in both sides, taking care not to over-tighten. When all 8 bolts are installed and tightened, then replace the two end caps.
- 3** Replace the fuse in the power supply.

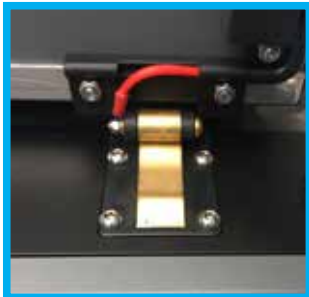


FIG. 40



FIG. 41



FIG. 42



FIG. 43



FIG. 43a



FIG. 44

- 1** To open the drawer, turn the supplied key to the right, then remove the key and pull on the blue aluminium handle. This will release the drawer from the frame.
- 2** For LED strip light function; pull the drawer out to full extension – the drawer will roll over the first (small stage) of an electrical bumper to supply power to the LED strip light.
- 3** To keep the storage drawer open on a slope; pull the drawer out a little further, the electrical contact will remain working and the drawer will then roll onto a stronger stage bumper which is the patented stay open/electrical contact device. This will keep the drawer open.
- 4** The LED strip light can be turned off by the recessed switch on the outer side of the front panel. The LED strip light will only work when the drawer is fully open. This prevents leaving the light on and closing the drawer.
- 5** To close the storage drawer; the drawer can be pushed closed without pulling the handle, a small push on the drawer face will push the drawer rollers over the stay open device.
- 6** The drawer can be pushed shut and key locked if necessary.

- Clean any exposed parts regularly to ensure that bearings and bearing tracks remain free from dirt, sand and grit, and spray bearings with dry silicon lubricant.
- Wipe down powdercoated aluminium panels with clean, warm, soapy water using a soft cloth. Do not use harsh chemicals or thinner based cleaners on your Explorer Aluminium Storage Drawer System.
- If Aluminium panels are gouged, chipped or scratched, try touching up the damaged area with closely matching paint.
- The LED Strip Light is designed to turn on at full drawer extension.  
If the LED strip does not light up on full extension - first check power supply then check the brass contacts are clean underneath the rear of the drawer - check that the fuse in the fuse block is ok.
- Carpet can be vacuumed - or wiped with a wet sponge.
- Trim can be touched up with a black permanent marker pen.

**Address:**

43 Harrington Street,  
Arundel QLD, 4214

ABN: 50 150 429 566

**Phone:**

+61 7 5594 6664

**Email:**

[sales@msa4x4.com.au](mailto:sales@msa4x4.com.au)

**Website:**

[msa4x4.com.au](http://msa4x4.com.au)

**All MSA 4X4 Accessories products are designed and manufactured to the highest quality standards to perform as they should. We stand behind our products with a Lifetime Manufacturer's Warranty. All claims under this warranty should be made by returning the product at your cost to MSA 4X4 Accessories Pty Ltd, 43 Harrington Street, Arundel, QLD 4214, with the detail of the fault, proof of purchase, proof of identification and vehicle fitment details where relevant. Lifetime manufacturer's warranty applies to the original purchaser only.**

If we determine that an MSA 4X4 Accessories product is defective in materials or workmanship during the Lifetime Warranty, we will either repair or replace the product. Repair or replacement is solely at the discretion of MSA 4X4 Accessories Pty Ltd. This warranty does not apply to failure or damage caused by incorrect or faulty fitment, accidental or intentional damage, misuse or abuse, failure of other products, operation of the product outside of its environmental or technical specifications, or repair or modification carried out by anyone other than MSA 4X4 Accessories Pty Ltd. No charges will be accepted for external labour or materials.

Lifetime warranty is applicable to all MSA 4X4 Accessories Fridge Slides, Fridge Barriers, Storage Drawers, and steel or aluminium products, excluding MSA 4X4's Driving Mirrors & Power Panels. MSA 4X4 Accessories Lifetime warranty does not cover any coating faults, rust, scratches, chips, carpet or battery packs. Fabric product Lifetime Warranty covers all manufacture and fabric components. Lifetime Warranty will not cover any fading of fabrics.

MSA 4X4 Accessories products are designed for lifestyle applications. Due to the harshness of the mining environment, MSA 4X4 Accessories products used in mining applications that may be operating outside of their environmental and technical specifications, are therefore excluded from a Lifetime Warranty. MSA 4X4 Accessories products used in mining applications are warranted for up to 1 year.

Our goods come with guarantees that cannot be excluded under the Australian Consumer Law. You are entitled to a replacement or refund for a major failure and for compensation for any other reasonably foreseeable loss or damage. You are also entitled to have the goods repaired or replaced if the goods fail to be of acceptable quality and the failure does not amount to a major failure.