



FITTING INSTRUCTIONS

930 & 930A BLANK MODULES



Image for illustration purposes only

CONTENTS

- 3** CONGRATULATIONS
- 4** GETTING STARTED:
- 5** IMPORTANT INFORMATION
- 6** FITTER'S QUICK INSTALLATION GUIDE
- 7** 3D DIAGRAM
- 8** FITTING DIAGRAM
- 9** BRACKET POSITIONS
- 10** DRAWER REMOVAL & REINSTALLATION
- 12** DRAWER MODULE PREPARATION LEFT
- 14** DRAWER MODULE PREPARATION RIGHT
- 16** DOUBLE DRAWER INSTALLATION
- 24** SINGLE DRAWER INSTALLATION LEFT
- 24** SINGLE DRAWER INSTALLATION RIGHT
- 25** DRAWER REMOVAL & INSTALLATION
AFTER THE DRAWERS HAVE BEEN COMPLETELY INSTALLED
- 26** OPERATING INSTRUCTIONS
- 27** CARE & MAINTENANCE
- 28** WARRANTY





CONGRATULATIONS ON YOUR PURCHASE OF A QUALITY MSA 4X4 DRAWER SYSTEM!

Years of design, development and manufacturing knowledge goes into every MSA 4X4 product to ensure that our products are the very best they can be!

Established in 2000, MSA 4X4 Accessories are the 4WD market leaders in quality Canvas products which include Certified ADR Compliant Canvas Seat Covers, Rear Wheel Bags, Rear Wheel Rubbish Bins, Vehicle Organisers and more.

We pride ourselves on our innovative products which include the world first, revolutionary Fridge Dropslide, the new patent pending Explorer Aluminium Storage Drawer System which delivers a whole new level of access to the drawer contents, the original Water Bra, fully adjustable air lumbar support systems, and an extensive range of 4x4 accessories that have stood the test of time.

As testament to our innovative culture, we have been awarded 19 patents in Australia & Internationally across our range of products including innovations currently within the patent process. We are a growing team with a vast knowledge of what works and what doesn't work out in the real world and constantly strive to deliver the highest quality product to our customers. We treat every product design with fear of failure in mind, ensuring our products are always the very best they can be. All our products are designed to be as simple as possible to use and are supported by our MSA 4X4 Lifetime Guarantee.

Our products are available through a network of over 600 stockists Australia wide.



4 **GETTING STARTED:** Here's what comes in the box



- 1 X** Drawer Module
- 2 X** Keys (located inside each drawer module)
- 1 X** Wing & Fit Kit box if ordered
- 1 X** Double Drawer Joining Kit if ordered
- 1 X** Crash Test Certificate

If anything is missing,
please contact us via msa4x4.com.au

IMPORTANT INFORMATION

It is important that you read and understand the below information before installing your new MSA 4X4 Explorer Aluminium Storage Drawer System.

MAINTAINING ADR COMPLIANCE OF YOUR DRAWER SYSTEM

MSA 4X4 storage drawer systems have been legally crash tested and are supplied as an ADR compliant drawer module and fit kit system when the correct number fit kits for the EWK930-LEFT / EWK930A-LEFT and EWK930-RIGHT / EWK930A-RIGHT are used for the installation and joining of the drawer modules. Failure to use a matching fit kit or components for the particular vehicle installation or the use of other components to install MSA 4X4 storage drawers may void the ADR compliance of the storage drawer system and/or the warranty.

UNDERSTANDING DIFFERENCES BETWEEN LEFT & RIGHT HAND SIDE MODULES:

MSA 4X4 storage drawer systems are of a modular design, they do come in left and right hand side modules as the need for wires and switches must enter the frame from one side. The modules are clearly marked “left” and “right” on the packaging boxes. On the right (RHS) drawer, the wiring and the LED light switch is on the RHS of the drawer. On the left (LHS) drawer the wiring and switch is on the LHS of the drawer.

FRONT & REAR DEFINITIONS FOR FITTING INSTRUCTION PURPOSES:

The “Front” is related to the front face of the drawer system, where the lock is located. (Towards the rear of the vehicle.) The “Rear” is related to the rear of the drawer system. (Towards the front of the vehicle.)

MAINTAINING ADR COMPLIANCE OF YOUR CHILD RESTRAINTS:

ADR Compliant Child Restraint points are installed as standard in MSA 4X4 Storage drawer systems. The anchor point bolt for the Child Restraint is marked on the rear of the drawer. This is the second bolt down from the top. The bolt installed is an M8 x 30mm High Tensile bolt, please use this bolt for child restraint anchors. Do not replace this bolt as it will result in the child restraint anchor not being ADR compliant.

MAINTAINING ADR COMPLIANCE OF CARGO BARRIER INSTALLATION:

The top two bolts on both sides of the rear frame can be used for Cargo Barrier mounting, these points have been crash tested and are ADR Compliant when used with the supplied bolts.



The same **second bolt down** from the top only can be used as a **Cargo Barrier mount** and a **Child Restraint point** from the same bolt if needed. (see image above)

6 FITTER'S QUICK INSTALLATION GUIDE

930 & 930A BLANK DRAWER MODULE

- 1** Prepare the vehicle by removing the tray liner or carpet if installed.
- 2** Clean, vacuum and wipe down the tray or the rear of the wagon.
- 3** Remove drawer from frame if need - not necessary but easier for handling and installing the frames.
- 4** Prepare both drawers by installing any wing brackets and spacer blocks if needed
- refer to fitting diagram on page 8 for more detailed instruction.
- 5** Place Right (driver's) side module in to vehicle.
- 6** Place Left (passenger's) side module into vehicle.
- 7** Join drawers with join kit bolts and tighten if double drawer kit is being installed.
- 8** Centre the drawer frame in the car.
- 9** Drill holes in the floor through the cross channels and install bolts & washers as per the fitting diagram on page 8.
- 10** Do any wiring required for power supply to drawer frames.
- 11** Re-install drawers into frame.
- 12** Check that drawers function correctly.
- 13** Install the wing panels.
- 14** Install the large frame top panels.
- 15** Install top panel and front trim and install wing panel trims.

EXPLORER ALUMINIUM DRAWER SYSTEM

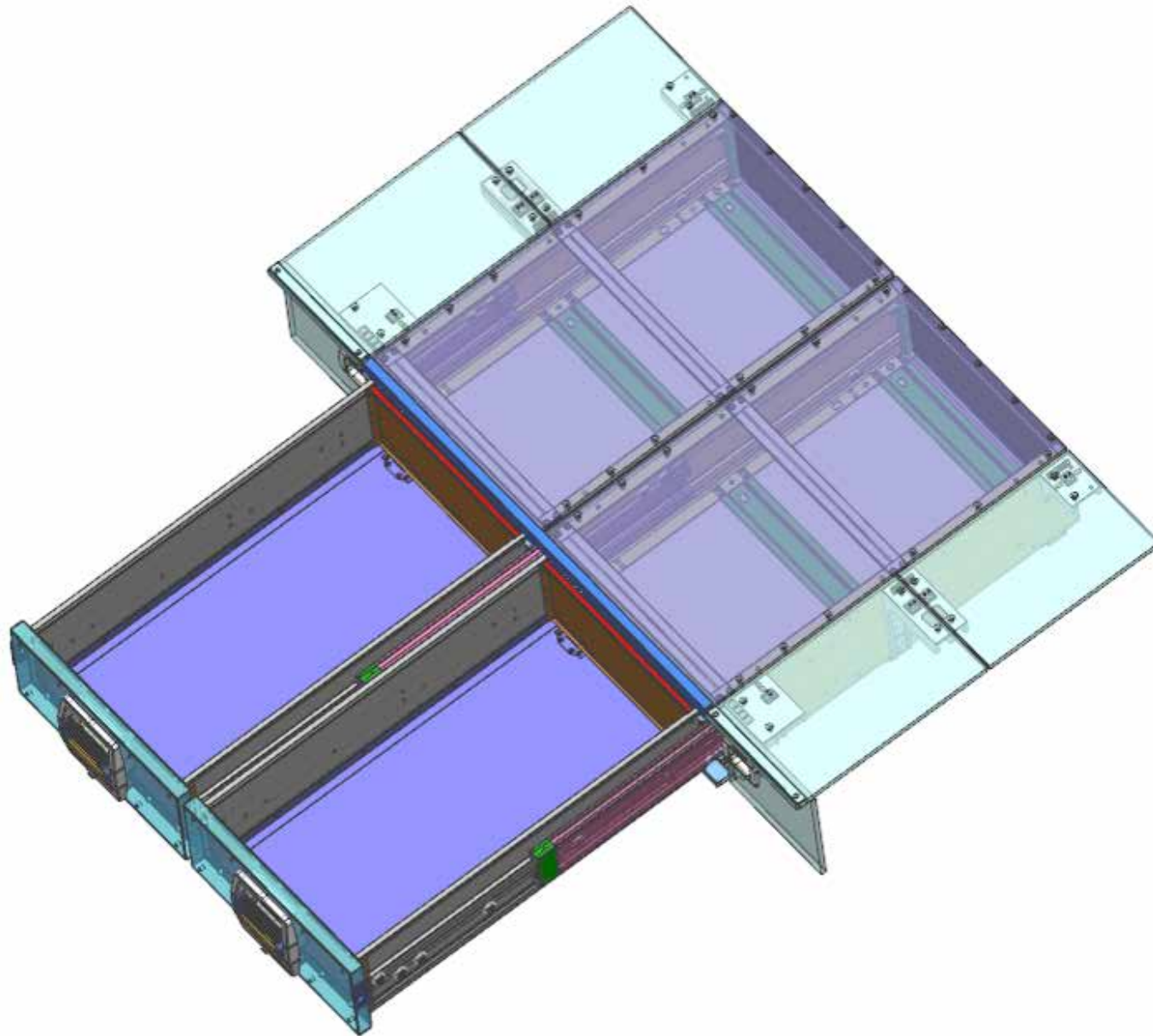

930 & 930A FITTING DIAGRAM

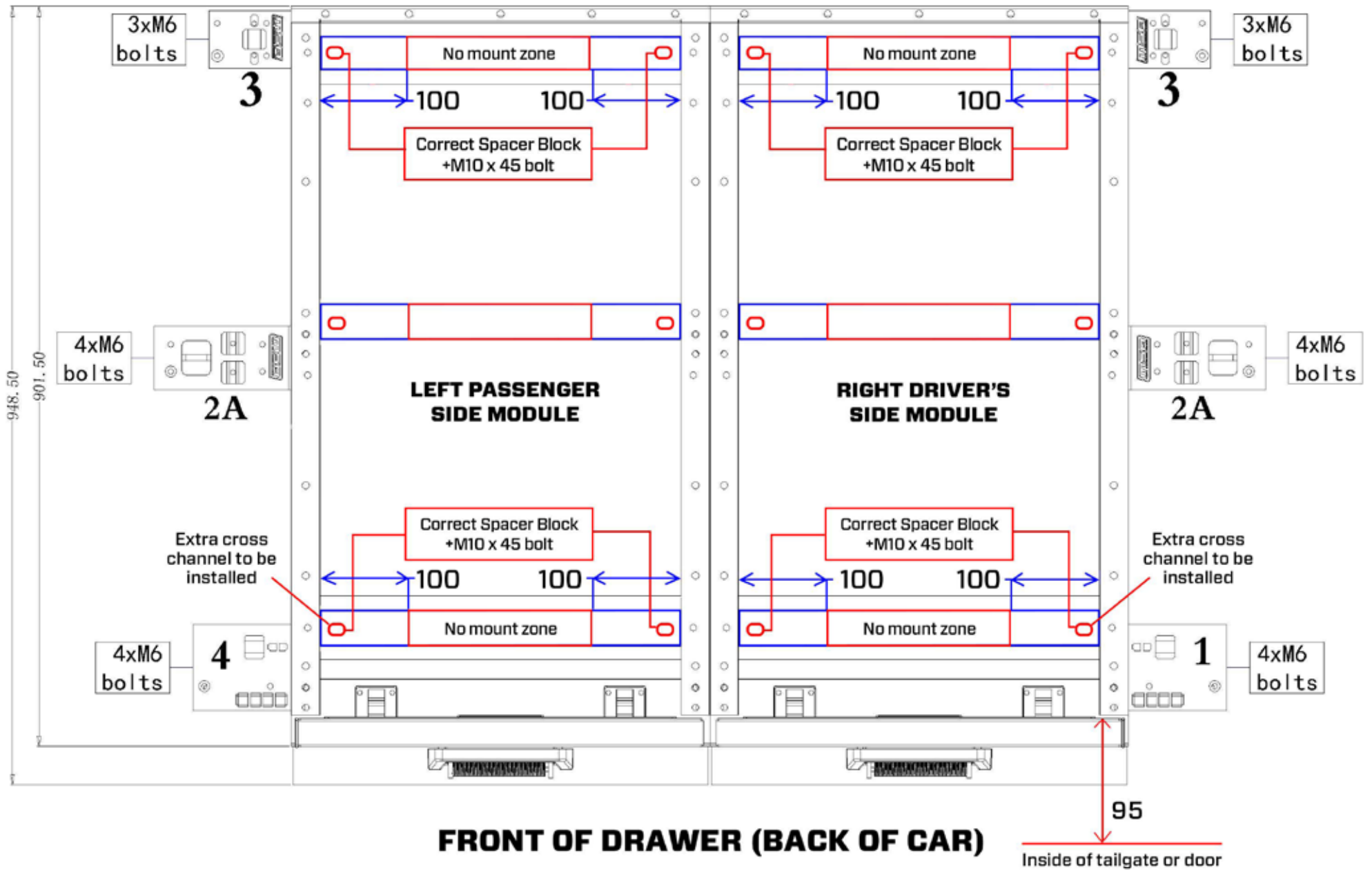

BRACKET POSITIONS

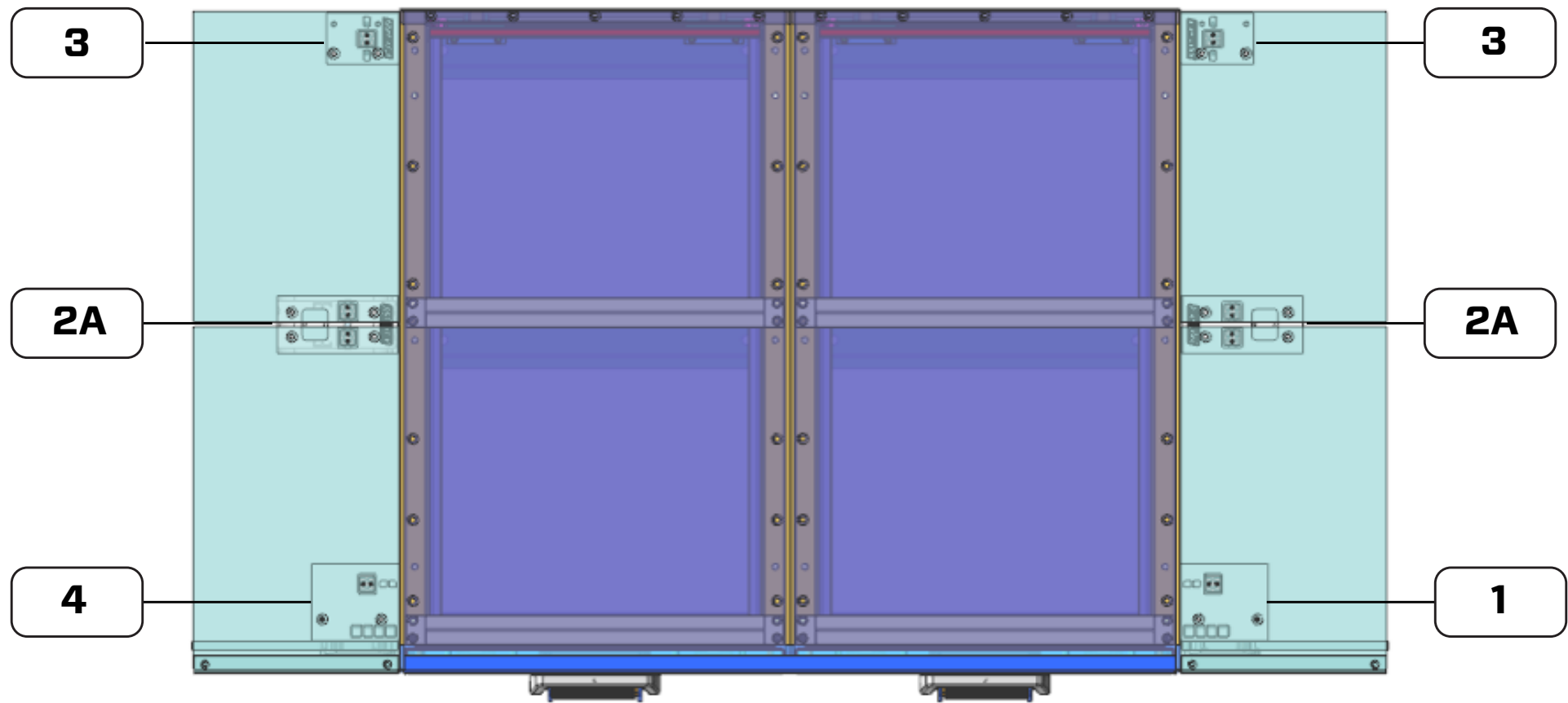

10 DRAWER REMOVAL

Note: Most times it is easier to remove the drawer from the frame for easier installation

PLEASE FOLLOW THESE DRAWER MODULE PREPARATION INSTRUCTIONS TO ENSURE THAT YOUR NEW EXPLORER ALUMINIUM STORAGE DRAWER SYSTEM IS INSTALLED CORRECTLY.

1. Note: Drawer preparation requires the drawer to be open to full extension. A long flat surface is required for this preparation.
 2. Tip: A cordless drill, hex bit to 1/4 and 3/8 drive socket adapters, a set of 1/4 and 3/8 drive hex head bits and a set of metric spanners are recommended for installation ease.
 3. Remove one drawer module from its packaging and place on a flat surface – a 2.4 metre flat bench is recommended.
 4. Remove the carpeted top panel by removing the 21 x M6 countersunk Allen head bolts (this is quickest with a cordless drill, 1/4 drive adapter and 1/4 drive 4mm hex head socket bit) set the panel aside. **(FIG. 1 & 1a)**
- DRAWER REMOVAL**
5. The drawers can be installed with or without removing the drawers from the frame. It is easy and quick to remove the drawer from the frame which makes it easier to handle and install.
 6. If you choose to remove the drawer, start by fully extending the drawer so that the brass electrical contacts and stay open device are completely engaged. **(FIG. 2)**
 7. Support the end of the open drawer near the lock with a corner piece of packing from the box. **(FIG. 3)**

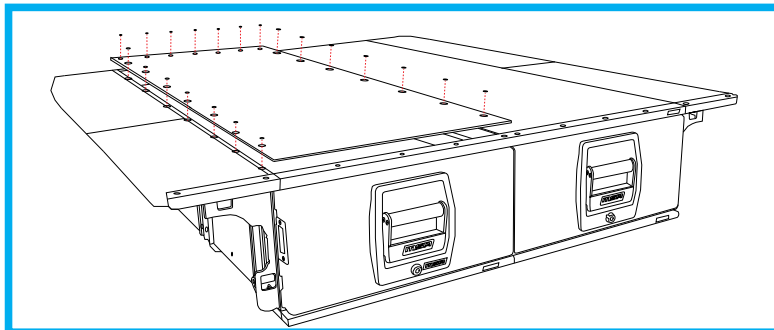

FIG. 1



FIG. 1a

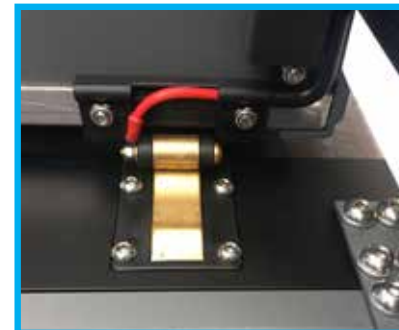

FIG. 2



FIG. 3

8. You can now see the internal workings of the drawer system. Remove the two black injection moulded guide stopper blocks by removing the 4 x 4mm allen head bolts in each block. This is best done with a small hex bit attached to a flexible drive shaft and a cordless drill. **(FIG. 4 & 4a)**
9. Repeat this on the opposite side of the drawer.
10. Once both blocks are removed, the middle aluminium extrusions on each side of the drawer can be carefully slid forward until the drawer is clear of the frame. **(FIG. 5 & 5a)**
11. The drawer can now be moved away, taking care not to allow the loose centre extrusion to run out.



FIG. 4



FIG. 4a



FIG. 5



FIG. 5a

12 DRAWER MODULE PREPARATION LEFT

LEFT SIDE (PASSENGER) DRAWER PREPARATION

If no wing kit is installed, skip to page 16.

1. If the drawer is going to be left in during installation, open the drawer to its full extension by pulling on the blue lock handle. Ensure drawer is pulled out to full 100% extension and the stay open devices are engaged in the base of the frame. To keep drawer level while installing wing brackets, place a small piece of angular packing cardboard under the lock end of the drawer for support. **(FIG. 6)**
2. Starting with bracket number **(4)** install at the front of the LHS of the frame through the pre-drilled holes using 4 x M6 hex head bolts, use a 10mm socket and extension bar to install these bolts, flat and spring washers. Install the bolts from the inside of the frame out into the bracket. Leave all bolts loosely installed until all 4 are started, then align the bracket parallel with the front of the drawer frame and tighten all four bolts with the 10mm socket. **(FIG. 7 & 7a)**
3. Install bracket number **(2A)** in the middle pre-drilled holes of the LHS of the drawer frame following the same procedure as for bracket 1. **(FIG. 8)**



FIG. 6



FIG. 7



FIG. 7a



FIG. 8

4. Install bracket number ③ to the rear LHS of the frame by first removing the top two M8 high tensile bolts from the top of the frame. **(FIG. 9)**
PLEASE NOTE: only three (3) bolts are to be used in this bracket, the top two and one lower at the rear of the frame. **(FIG. 9A)** Use the 3 x M6 allen head bolts and washers. Following the same tightening procedure as brackets 1 and 2 to fasten the bracket. **(FIG. 9B)**
5. The centre cross channel on the 930 & 930-A needs to be moved from the centre position to the forward set of holes. Refer to fitting diagram on page 8.
6. Install the 2 x C clips onto the underside of the wing panels and then install the side wing panels on both sides of the drawers. To assist with the frame alignment in tray, centralise the drawer frame in the vehicle by measuring to a similar reference point from both sides of the vehicle tray. **(FIG. 10)**



FIG. 9

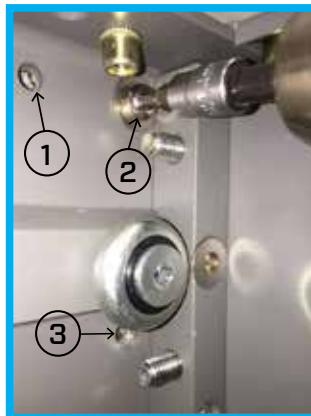

FIG. 9a



FIG. 9b



FIG. 10

14 DRAWER MODULE PREPARATION RIGHT

RIGHT SIDE (DRIVER) DRAWER PREPARATION

1. If the drawer is going to be left in during installation, open the drawer to its full extension by pulling on the blue lock handle. Ensure drawer is pulled out to full 100% extension and the stay open devices are engaged in the base of the frame. To keep drawer level while installing wing brackets, place a small piece of angular packing cardboard under the lock end of the drawer for support. **(FIG. 11)**
2. Starting with bracket number ① install at the front of the RHS of the frame through the pre-drilled holes using 4 x M6 hex head bolts, use a 10mm socket and extension bar to install these bolts, flat and spring washers. Install the bolts from the inside of the frame out into the bracket. Leave all bolts loosely installed until all 4 are started, then align the bracket parallel with the front of the drawer frame and tighten all four bolts with the 10mm socket. **(FIG. 12 & 12A)**
3. Install bracket number ②A in the middle pre-drilled holes of the RHS of the drawer frame following the procedure for bracket 1. **(FIG. 13)**



FIG. 11



FIG. 12



FIG. 12a



FIG. 13

4. Install bracket number ③ to the rear RHS of the frame by first removing the top two M8 high tensile allen heads from the top of the frame. (FIG. 14)

PLEASE NOTE: **only three (3) bolts are to be used in this bracket,** the top two and one lower at the rear of the frame. (FIG. 14a) Use the 3 x M6 allen head bolts and washers. Following the same tightening procedure as brackets 1 and 2 to fasten the bracket. (FIG. 14B)

5. The centre cross channel on the 930 & 930-A needs to be moved from the centre position to the forward set of holes. Refer to fitting diagram on page 8.
6. Install the 2 x C clips onto the underside of the wing panels and then install the side wing panels on both sides of the drawers. To assist with the frame alignment in tray, centralise the drawer frame in the vehicle by measuring to a similar reference point from both sides of the vehicle tray. (FIG. 15)



FIG. 14

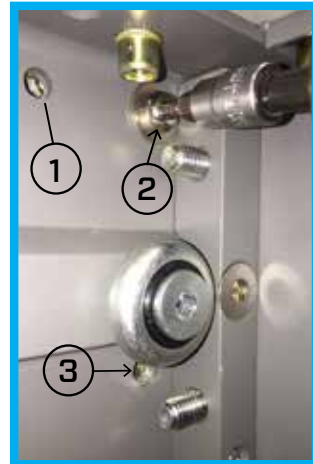

FIG. 14a



FIG. 14b



FIG. 15

16 DOUBLE DRAWER INSTALLATION

DOUBLE DRAWER INSTALLATION

1. Install the extra cross channel supplied in the kit to the front of the base frame with the 8 x M8 allen head bolts and spring washers. Start the 4 bolts on each side first then after all 8 bolts are started they can be tightened. Repeat for both modules. **(FIG. 16, 16a & 16b)**
2. With assistance, carefully place the RHS drawer module into the vehicle and push to RHS.
3. Again with assistance, now place the LHS drawer module into the vehicle.
4. Now the drawer frames need to be joined.
5. Open both drawers if the drawers are still in the frame, taking care to support under the front end of the drawer.
6. There are 8 x M8 Allen Head bolts and nyloc nuts used to join the drawer frames. Starting at the rear of the frame at the top, place an M8 bolt through the top hole that is aligned in the frame for joining. It is easiest to use a cordless drill with adaptor and an M5 hex head socket bit and a 13mm spanner. Place the M8 nyloc nut on the other side of the frame. Leave the bolt loose. **(FIG. 17)**
7. Working forwards install all 4 of the top row of M8 bolts in the same manner. Leave the bolts loose.
8. Working from the front back now install the bottom 4 x M8 bolts and nuts. Leave the bolts loose.
9. Starting at the rear top of the frame, ensure frame tops are perfectly level and tighten the rear top bolt.
10. Repeat the same on the front top bolt ensuring both frames are perfectly level then tighten the nut.
11. Now work front to back on the lower row of 4 bolts and tighten all. Then tighten the remaining top 2 bolts on the top row.
12. The drawers can now be centralised in the car by measuring both sides of the frame to similar places of the vehicle tray. **(FIG. 18 & 18A)**



FIG. 16



FIG. 16a



FIG. 16b



FIG. 17



FIG. 18

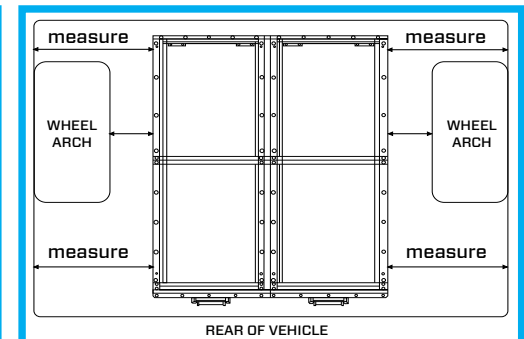
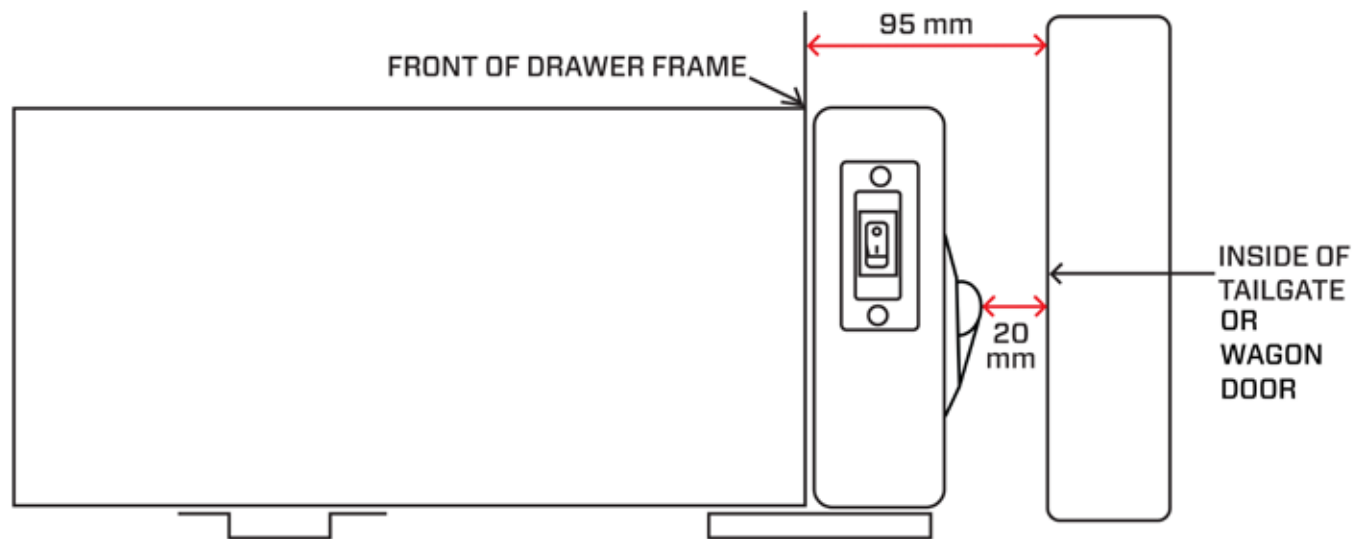

FIG. 18a

13. Carefully close the tailgate of the vehicle and check to ensure there is at least 20mm of clearance to the front of the handle lock. This will determine the best front to back position for the drawer. If the drawer has been removed, measure back from the tailgate 95mm to the front side of the drawer frame for best frame position, as per the diagram below.
14. Now the M10 High Tensile fitting bolts, washers and blocks need to be installed.
15. Refer to the fitting diagram on page 10 for hole measurements and exactly where to drill.
Please Note: There is a fitting zone on the cross channels. Do not drill holes any further than 100mm from the inside base of the drawer frame - page 11.
16. Before drilling through the tray, ensure there is nothing under the tray that could be damaged by drilling.



18 DOUBLE DRAWER INSTALLATION

17. Taking care that the frame has not moved, mark the two outside rear holes using measurements from the fitting diagram
NOTE: These measurements are very specific, please be careful to follow them. Drill a pilot hole using a 6mm drill bit through the tray, then follow with an 11mm drill bit to allow small clearance for the M10 bolt. (FIG. 18)
18. Remove drilling shavings by vacuum to clean the tray. (FIG. 19)
19. Using a small brush, paint the exposed metal of the drilled hole with a coat of paint to seal the metal and prevent future corrosion. (FIG. 20)
20. A correct sized spacer block needs to be installed under the cross channel. Please select a spacer block from the kit supplied that will sit flush level with the top of the vehicle's tray corrugations. (FIG. 21 & 21A)



FIG. 18



FIG. 19

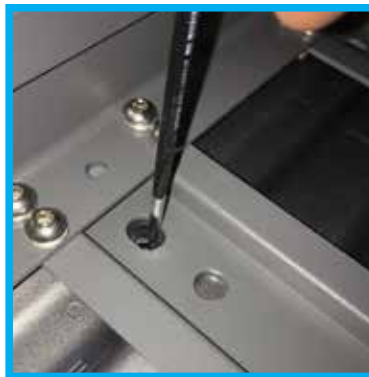

FIG. 20



FIG. 21



FIG. 21a

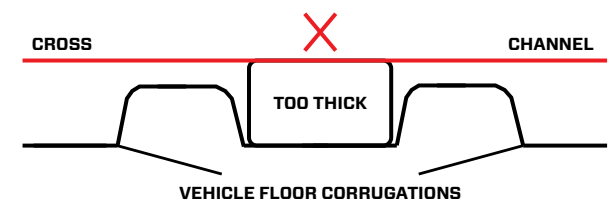
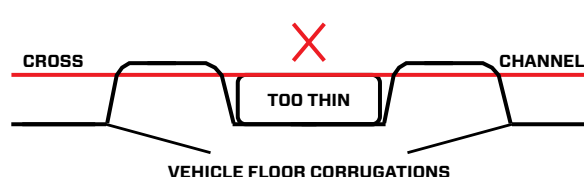
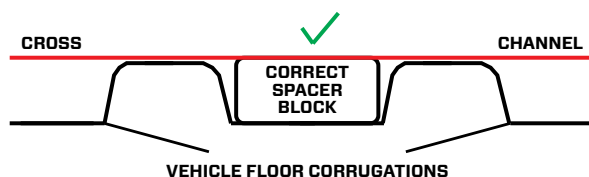

21. Install the two 10mm High Tensile front bolt and washer assemblies on each rear side of the drawer frame as per figure drawing and (FIG. 22 & 22a)
22. Check that the frame has not moved by measuring at rear and front of the drawer frame. Now tighten both bolts with an M8 hex head socket bit and torqued down to 30ftlb (40.6 Nm) using a torque wrench. (FIG. 23 & 23a)
23. Again check frame measurements to the side of the tray at the front of the drawer frame and repeat the drilling, installation and tightening of the front 2 x M10 high tensile bolt and washer assemblies.
24. The frame is now installed and it is time to do the power supply to the drawer frame.
25. Please be sure to cable tie or tape any wires out of the way of the sliding drawer base.

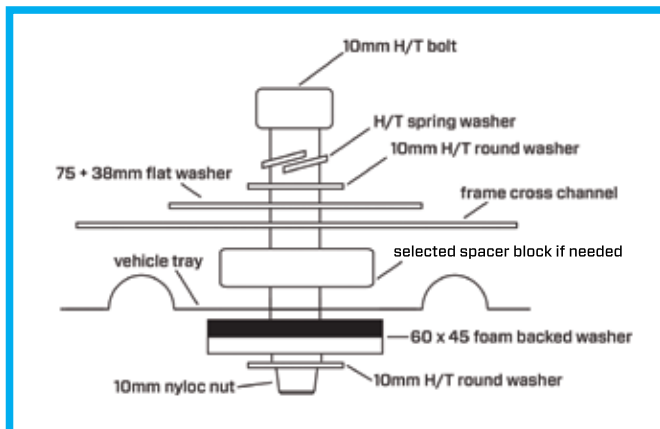

FIG. 22



FIG. 22a



FIG. 23



FIG. 23a

20 DOUBLE DRAWER INSTALLATION

DRAWER RE-INSTALLATION

- 26.** Now it is time to place the drawers back into the frame. First remove the fuse in the power supply to the drawers, as allowing the drawer frame to touch the main frame may blow the fuse. The best way to re-install the drawer into the frame is to rest the rollers at the rear base of the drawer into the end of the contacts on the base frame (**FIG. 24**) Then, hold the drawer horizontally parallel with the frame and then slide the two centre slide extrusions in to the roller bearings. (**FIG. 25 & 25a**)
- 27.** After the centre extrusion has passed the middle roller bearings, the rear stopper blocks can be re-installed by placing the blocks in the aligning holes and tightening the 4 x M4 allen head bolts on each side. Please ensure all these 8 bolts have the spring washers installed. Do not over-tighten these bolts, just firm is enough (a 7-9 on the screw clutch setting on a cordless drill is a good guide). Repeat this process for the second drawer. (**FIG. 26**)
- 28.** The fuse to the power supply can now be installed and the drawer LED strip lights check for function.
- 29.** Now check that the power supply to the drawers is functional by opening the drawer to full extension so that the brass electrical contacts under the rear of the drawer frame, make contact. Check switch function. The LED Strip inside the drawer should light up. When pushing the drawer back in to the frame, the LED light will immediately switch off, to prevent the light from accidentally being left on.

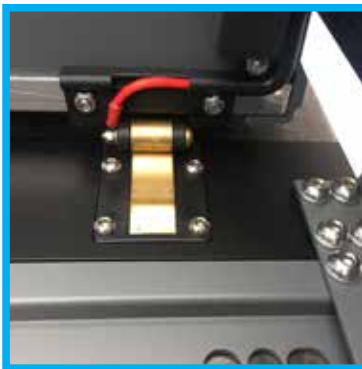

FIG. 24



FIG. 25



FIG. 25a



FIG. 26

- 30. It is now a good time to wipe out the aluminium channels and give them a small spray of dry silicone lubricant. (This does not get done in the assembly process as it can attract grit from the installation process).
- 31. Check that the drawers function correctly.
- 32. The top panels can now be installed back onto the drawer frames. Place the panel in position and locate a bolt thread in each corner of the top. **(FIG. 27)**
Ensuring the 4 corner bolts have started, the remaining 13 x top hex head bolts can now be re-installed and tightened on each panel. These need only enough torque to pull the bolt head down to carpet level. **(FIG. 28)**
Tip: A very low 3 torque setting on a cordless drill is enough to tighten these bolts.
- 33. The wing panels can now be cut to shape and carpeted. This is best done by making a cardboard template cut to the shape of the vehicle tray. Transfer this template to the timber wing panels and trim the marine ply carefully with a jigsaw. Remove all sawdust and the carpet can now be adhered to the timber by using a contact adhesive. After carpeting the upper and lower sides and the ends of the wing panel. Install the C clips on the underside of the panel and the panel can now be clipped into the wing brackets. Repeat this process for all side and rear wing panels.



FIG. 27

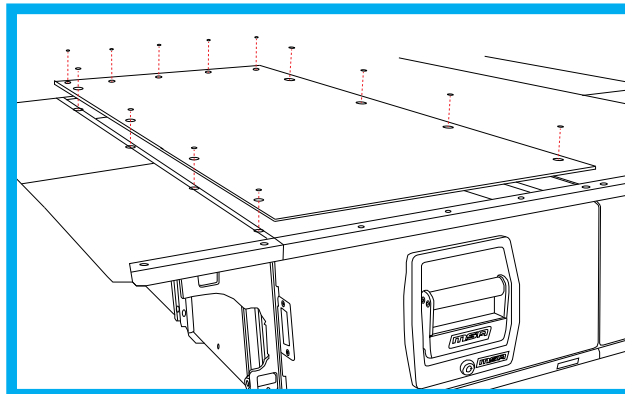

FIG. 28

22 DOUBLE DRAWER INSTALLATION

34. The double width top panel trim can now be installed. Push the trim firmly over the end of the double carpeted panels and centralise. Install the 10 x small stainless steel countersunk self-tap screws in the trim taking particular care to install them in a perfect vertical line. **(FIG. 29, 29a & 29b)**
35. The matching wing panel trims can now be installed using the same process. The wing panel trims may need to be cut down to length. Allow 4mm in at each end of the wing panel. Cut the trim then mark and drill a 4mm hole, then use a countersink bit to countersink the top of the hole. This can be coloured in with a black permanent marker pen to hide the bare aluminium. **(FIG. 30, 30a, 30b & 30c)**
36. The drawer system is now completely installed and ready for use.

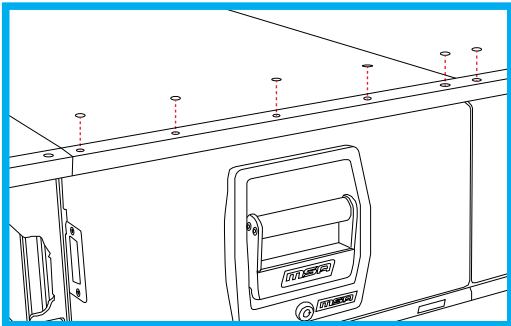

FIG. 29



FIG. 29a



FIG. 29b



FIG. 30



FIG. 30a



FIG. 30b



FIG. 30c

- 37.** If a slide is to be mounted to the top of the drawer panels, the wing panels can be bolted down to the brackets with 4 x M6 countersunk Allen Head bolts supplied in the wing kit. Use a sharp pointed device to locate the 4 x holes under the carpet in the wing panels. The 4 x M6 bolts can then be installed through these holes into the threads in the wing brackets and tightened down to a flush carpet level. There are 4 x M6 bolts in each panel. **(FIG. 31)**
- 38.** If carpet is to be installed on the side of the drawer, this can be installed using a spray contact adhesive.
(Single drawer side frame carpet pieces can be purchased for your Explorer Aluminium Storage Drawer System).



FIG. 31

24 SINGLE DRAWER INSTALLATION

SINGLE DRAWER INSTALLATION LEFT

Refer to double drawer installation **page 12 & 13**, ignoring any instructions referring to double drawers.

SINGLE DRAWER INSTALLATION RIGHT

Refer to double drawer installation **page 14 & 15**, ignoring any instructions referring to double drawers.

The MSA 4X4 Aluminium Drawer systems have been expertly designed to allow easy removal of the drawers from the frames if needed, without the need to remove the top decks of the system.

1. Open the drawers to full extension and the stay open contacts engage at the underside rear of the drawer. (FIG. 32) Support the front of the drawer with some packing cardboard if possible. (FIG. 33)
2. Remove the fuse from the power supply to the drawers.
3. On either side of the sliding frame are two black injection moulded stopper blocks. These two blocks need to be removed to remove the drawer from the frame.
4. With a small screwdriver, pry the end cap away from the block, taking care not to mark the cap. Once removed, this will then give access to 4 x M4 allen head bolts with spring washers. (FIG. 34)
5. Remove these 4 bolts on each side with a hex bit and take care not to lose the washers. (FIG. 35 & 35a)
6. After the two blocks have been removed, the two middle pieces of the over extension slide can be slid back into the frame and out of the way. (FIG. 36)
7. The drawer is now completely free from the frame and just resting on the contacts. It can be lifted away from the frame.

To re-install the drawers, follow the procedure in reverse, taking care to align the middle sliding extension carefully to not cause any marking.

1. Sit the drawer rollers on the two contacts at the front of the frame. (FIG. 32)
2. Push the drawer three quarters of the way in to the middle slide extension while pulling the extensions out forward towards the front of the drawer frame. The stopper blocks can now be installed in both sides, taking care not to over-tighten. When all 8 bolts are installed and tightened, then replace the two end caps.
3. Replace the fuse in the power supply.

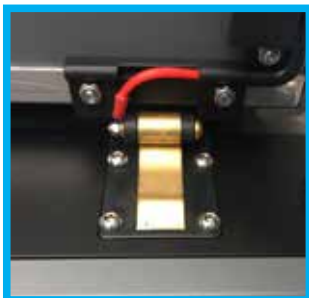

FIG. 32



FIG. 33



FIG. 34



FIG. 35



FIG. 35a



FIG. 36

26 OPERATING INSTRUCTIONS

- 1.** To open the drawer, turn the supplied key to the right, then remove the key and pull on the blue aluminium handle. This will release the drawer from the frame.
- 2.** For LED strip light function; pull the drawer out to full extension – the drawer will roll over the first (small stage) of an electrical bumper to supply power to the LED strip light.
- 3.** To keep the storage drawer open on a slope; pull the drawer out a little further, the electrical contact will remain working and the drawer will then roll onto a stronger stage bumper which is the patented stay open/electrical contact device. This will keep the drawer open.
- 4.** The LED strip light can be turned off by the recessed switch on the outer side of the front panel. The LED strip light will only work when the drawer is fully open. This prevents leaving the light on and closing the drawer.
- 5.** To close the storage drawer; the drawer can be pushed closed without pulling the handle, a small push on the drawer face will push the drawer rollers over the stay open device.
- 6.** The drawer can be pushed shut and key locked if necessary.

- Clean any exposed parts regularly to ensure that bearings and bearing tracks remain free from dirt, sand and grit, and spray bearings with dry silicon lubricant.
- Wipe down powdercoated aluminium panels with clean, warm, soapy water using a soft cloth. Do not use harsh chemicals or thinner based cleaners on your Explorer Aluminium Storage Drawer System.
- If Aluminium panels are gouged, chipped or scratched, try touching up the damaged area with closely matching paint.
- The LED Strip Light is designed to turn on at full drawer extension.
If the LED strip does not light up on full extension - first check power supply then check the brass contacts are clean underneath the rear of the drawer - check that the fuse in the fuse block is ok.
- Carpet can be vacuumed - or wiped with a wet sponge.
- Trim can be touched up with a black permanent marker pen.

28 LIFETIME GUARANTEE

All MSA 4x4 Accessories products are designed and manufactured to the highest quality standards to perform as they should. We stand behind our products with a Lifetime Manufacturer's Warranty.

All claims under this warranty should be made by returning the product at your cost to MSA 4x4 Accessories Pty Ltd, 43 Harrington Street, Arundel, QLD 4214, with the detail of the fault, proof of purchase, proof of identification and vehicle fitment details where relevant. Lifetime manufacturer's warranty applies to the original purchaser only.

If we determine that an MSA 4x4 Accessories product is defective in materials or workmanship during the Lifetime Warranty, we will either repair or replace the product. Repair or replacement is solely at the discretion of MSA 4x4 Accessories Pty Ltd. This warranty does not apply to failure or damage caused by incorrect or faulty fitment, accidental or intentional damage, misuse or abuse, failure of other products, operation of the product outside of its environmental or technical specifications, or repair or modification carried out by anyone other than MSA 4x4 Accessories Pty Ltd. No charges will be accepted for external labour or materials.

Lifetime warranty is applicable to all MSA 4x4 Accessories Fridge Slides, Fridge Barriers, Storage Drawers, and steel or aluminium products. MSA 4x4 Accessories Lifetime warranty does not cover any coating faults, rust, scratches, chips, carpet or battery packs. Fabric product Lifetime Warranty covers all manufacture and fabric components. Lifetime Warranty will not cover any fading of fabrics. MSA 4x4 Accessories products are designed for lifestyle applications. Due to the harshness of the mining environment, MSA 4x4 Accessories products used in mining applications that may be operating outside of their environmental and technical specifications, are therefore excluded from a Lifetime Warranty. MSA 4x4 Accessories products used in mining applications are warranted for up to 1 year.

Our goods come with guarantees that cannot be excluded under the Australian Consumer Law. You are entitled to a replacement or refund for a major failure and for compensation for any other reasonably foreseeable loss or damage. You are also entitled to have the goods repaired or replaced if the goods fail to be of acceptable quality and the failure does not amount to a major failure.



Address: [43 Harrington Street, Arundel QLD, 4214](#). ABN: [50 150 429 566](#)
Phone: [+61 7 5594 6664](#). Email: sales@msa4x4.com.au. Website: msa4x4.com.au