



# INSTALLATION GUIDE

## **BBT053/ BBC053/ BBCD053/ BBA053**

TOYOTA FORTUNER 2015+



- Ironman 4x4 BBT/ BBC/ BBCD/BBA053 Bull Bars fit to a Toyota Fortuner 2015+
- It will take about 4 hours to install.

**NOTE:** This product has been tested for air bag compatibility and therefore the mounting system **MUST NOT** be modified

**IMPORTANT:** Bull Bar installations should only be done by a qualified person and it is the responsibility of this person to ensure correct fitment.

1. Before installation check bull bar application is compatible with your vehicle.

2. Mask front bumper bar as shown.



3. Use supplied template to mark cut lines on bumper bar as shown.



4. Mark cut line across the front of the bumper.  
Centre section needs to be 40mm below crease in bumper bar as shown.



5. Remove grill, front bumper bar, bumper reinforcement and lower bumper support brackets.



6. Cut plastic air-deflectors along lines as shown to allow fitment of bull bar to bracket.



7. Fit inner and outer chassis support brackets with supplied hardware.

NOTE: If fitting recovery points do so now.



8. Fit winch bracket to vehicle using M12 hardware supplied.



9. It is recommended to wire lights at this point for easier access to connection points  
See wiring diagram on pages 8.



10. If winch is being installed, refer to winch installation instructions Pages 6 - 7.

11. Cut bumper bar along lines marked in step 3 and refit to vehicle.

NOTE: Cut flares in line with bumper bar cut.



12. Re-fit grill and trim lower sections as shown.



13. Unwrap bull bar. Check over riders and light assemblies are tight in bull bar before installation.

14. Fit bull bar to chassis brackets using M12 bolts, flat washers, spring washers and nuts provided. Align with mudguard leaving a 10 - 15mm gap as shown.



15. Once bull bar is aligned with vehicle and tightened, drill through pinning holes (circled in red) between bull bar and chassis bracket and secure with M10 bolts, washers and nuts provided.



16. Connect lights.

17. Fit protection plates underneath the bull bar using M8 bolts, spring washers and flat washers provided.



18. Trim guard liners using protection plates as a guide.

Note: Cut guard liners approximately 25mm longer than required as this will secure them in position once tucked behind lip on protection plates.



# Winch Installation

1. Bolt winch to cradle with gearbox to the left hand side of vehicle and cable spooling from bottom of the cable drum using bolts and washers provided.



2. Bolt fairlead to recess in front of bull bar using bolts, washers and nuts provided.



3. Fit bull bar to vehicle referring to steps of bull bar fitting instructions.

4. Mount control box in desired location.



5. Connect three colour coded cables to the corresponding poles on winch motor.



6. Connect the thin black earth wire and negative battery cable to the earth connection on the opposite side of winch motor.



7. Run the positive and negative battery cables into the engine bay taking care to secure cables away from any sharp or moving objects.

8. Connect positive and negative battery cables main battery of vehicle (Not Auxilliary Battery).

9. Attach breather hose to barb fitting on winch motor. Run hose to the highest available point in engine bay and cable tie in position. Cable tie hose away from any sharp, hot or moving objects.



# Wiring Diagrams

## PARK LIGHT & INDICATOR

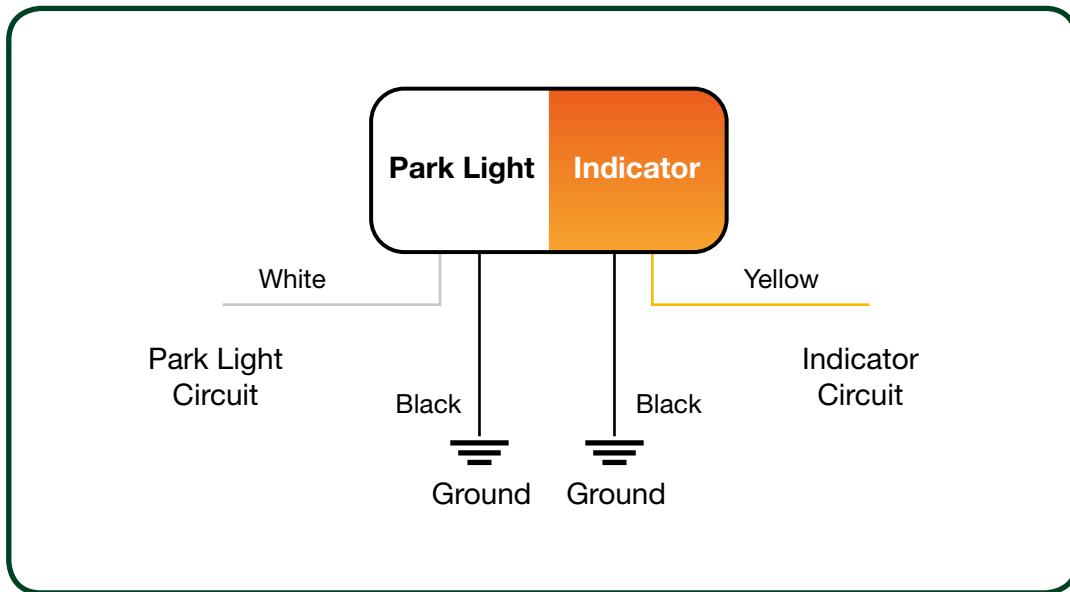

## FOG LIGHTS

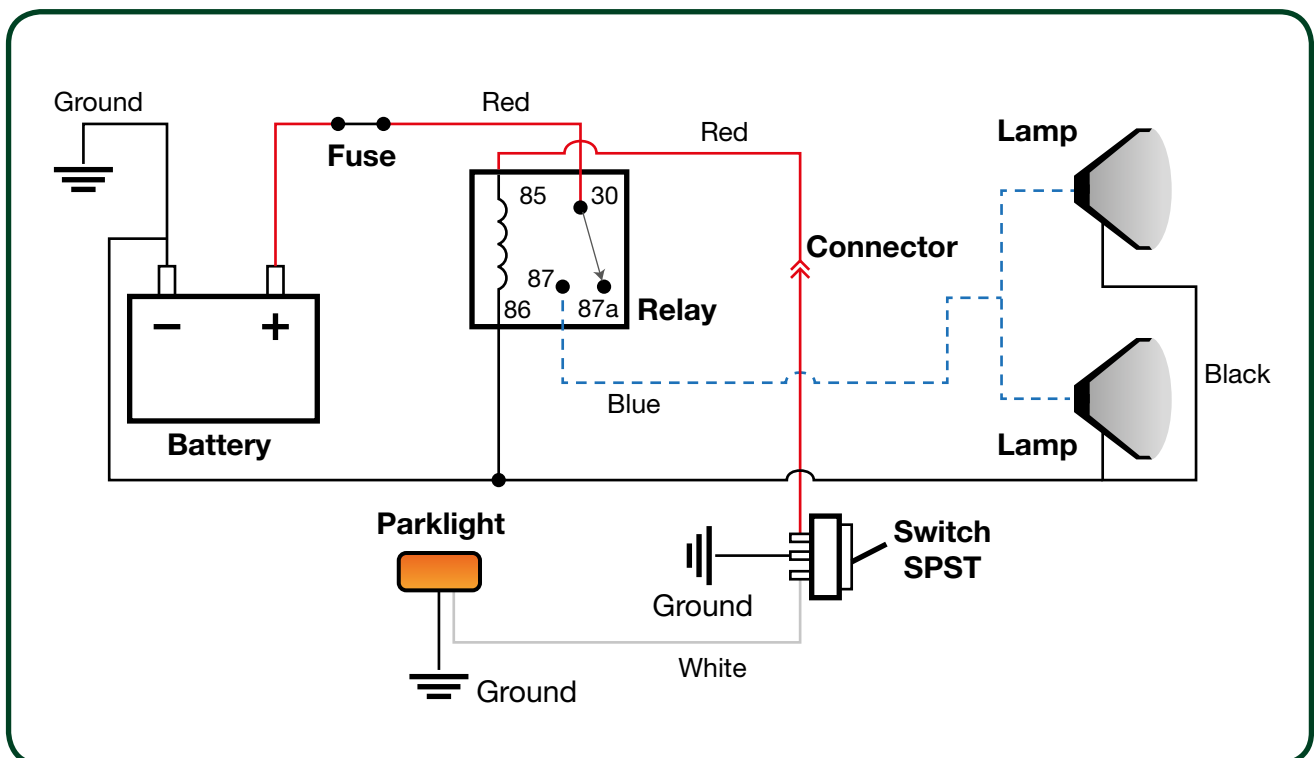





**JOIN HERE**  

**UNDER HEADLIGHT**

**TOWARD CENTRE OF VEHICLE**  



**TOYOTA FORTUNER 2015+  
BBT053/ BBC053/ BBCD053/ BBA053  
BULL BAR TEMPLATE**

**JOIN HERE**  

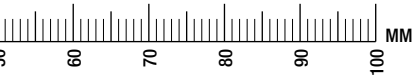

**JOIN HERE**



**JOIN HERE**



**TOYOTA FORTUNER 2015+  
BBT053/ BBC053/ BBCD053/ BBA053  
BULL BAR TEMPLATE**