



INSTALLATION GUIDE

BBT029/ BBC029/ BBCD029

TOYOTA PRADO 150



- Ironman 4x4 BBT/ BBC/ BBCD029 Bull Bars fit to a Toyota Prado 150.
- It will take about 3 hours to install.

NOTE: This product has been tested for air bag compatibility and therefore the mounting system **MUST NOT** be modified

IMPORTANT: Bull Bar installations should only be done by a qualified person and it is the responsibility of this person to ensure correct fitment.

1. Before installation check bull bar application is compatible with your vehicle.

2. Remove all mounting hardware holding lower section of front bumper bar to vehicle.

3. Locate and cutout cutting template at the end of this Instruction Guide.

4. Mask outer ends of bumper bar and place cutting template in position in line with joint between bumper and mudguard, and wheel arch.



5. Mark cut line and repeat for other side.



6. Mask a line across bumper level with the top edge of number plate recess and the bottom of the cut lines marked in previous step.



7. Cut along all lines and remove lower section of bumper and end sections.



8. Install pinch weld to cuts on ends of bumper.



9. Remove aluminium bumper reinforcement and mounting brackets.



10. Place U-Bolts in position around chassis from inside out, in front of radiator.



11. Attach mounting cradle to chassis using factory bolts and heavy duty flat washers.



12. Place reinforcing brackets over U Bolts outside chassis and loosely fit M10 nuts, springs and flat washers.

Fit M12 bolt, spring and flat washer to captive nut in chassis.

Place two heavy duty flat washers between reinforcing bracket and mounting cradle and secure with M12 bolts, flat washers, spring washers and nuts.

Tighten all bolts.

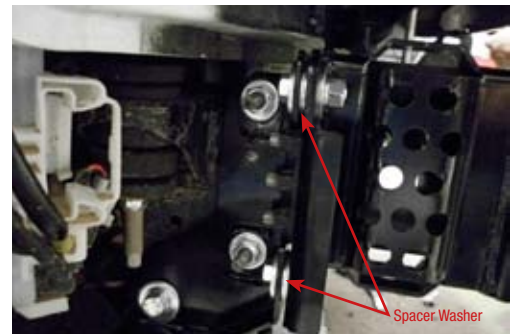

13. If winch is being installed, refer to winch installation instructions Pages 7 - 10.

14. Unwrap bull bar. Check over riders and light assemblies are tight in bull bar before installation.

15. Fit bull bar to chassis brackets using M12 bolts, flat washers, spring washers and nuts provided.



16. Align bull bar with vehicle and tighten all bolts.

17. Once bull bar is aligned with vehicle and tightened, drill through pinning holes (circled in red) between bull bar and chassis bracket and secure with bolts, washers and nuts provided.



18. Connect park lights, indicators and fog lights as per wiring diagrams on page 11 of Instruction Guide.

20. Fit protection plates underneath the bull bar using M8 bolts, spring washers and flat washers provided.



21. Trim left hand mudguard liner level with protection plate.



22. Trim right hand liner and secure to washer bottle with cable ties as shown.



Winch Installation

IMPORTANT: Before winch is installed to winch cradle, the clutch handle will need to be rotated to a more convenient position for access through bull bar.

1. Stand winch vertically on motor with gearbox facing upwards.



2. Undo and remove 2 chrome Allen head bolts which hold the gearbox to the tie rods.



3. Lift gearbox off winch.



NOTE: If shaft comes out of cable drum remove it from the gearbox and place it back into the drum making sure it engages with the brake.



NOTE: Also make sure that the drum support bush remains in the end of the drum support housing with the locating tang in the correct position.



4. Undo and remove 10 Allen head bolts that hold the gearbox housing to the drum support housing and rotate the drum support housing to the desired location.

For most Ironman 4X4 bull bars the gearbox will need to be rotated 2 holes in an anti clockwise direction. Make sure the gearbox gasket does not tear.



5. Re-install 10 bolts and tighten firmly.
NOTE: Take care not to over-tighten.



6. Refit gearbox to winch, refit and tighten Allen head bolts into tie rods.



7. Bolt winch to cradle with gearbox to the left hand side of vehicle and cable spooling from bottom of the cable drum using bolts and washers provided.

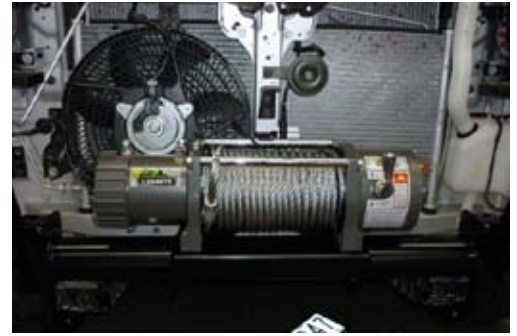

8. Bolt roller fairlead to recess in front of bull bar using bolts, washers and nuts provided.



9. Fit bull bar to vehicle referring to steps 14 - 20 of bull bar fitting instructions.

10. If winch control box is being fitted to top of bull bar remove control box bracket from control box.

11. Place control box on top of centre pan of bull bar with socket for hand controller facing outwards from vehicle. Mark position of the four mounting bolts.

Drill four holes to 6.5mm. Rust proof and de burr and attach control box to bar.



12. Connect three colour coded cables to the corresponding poles on winch motor.



13. Connect the thin black earth wire and negative battery cable to the earth connection on the opposite side of winch motor.



14. Run the positive and negative battery cables into the engine bay taking care to secure cables away from any sharp or moving objects.

Connect negative battery cable to the main battery.

15. Find a convenient location close to main battery to mount battery isolation switch.

Connect positive battery cable to one side of isolation switch and connect other side to the positive battery terminal of main battery.



16. Once completed, refer back to step 14 of bull bar fitting instructions.

Wiring Diagrams

PARK LIGHT & INDICATOR

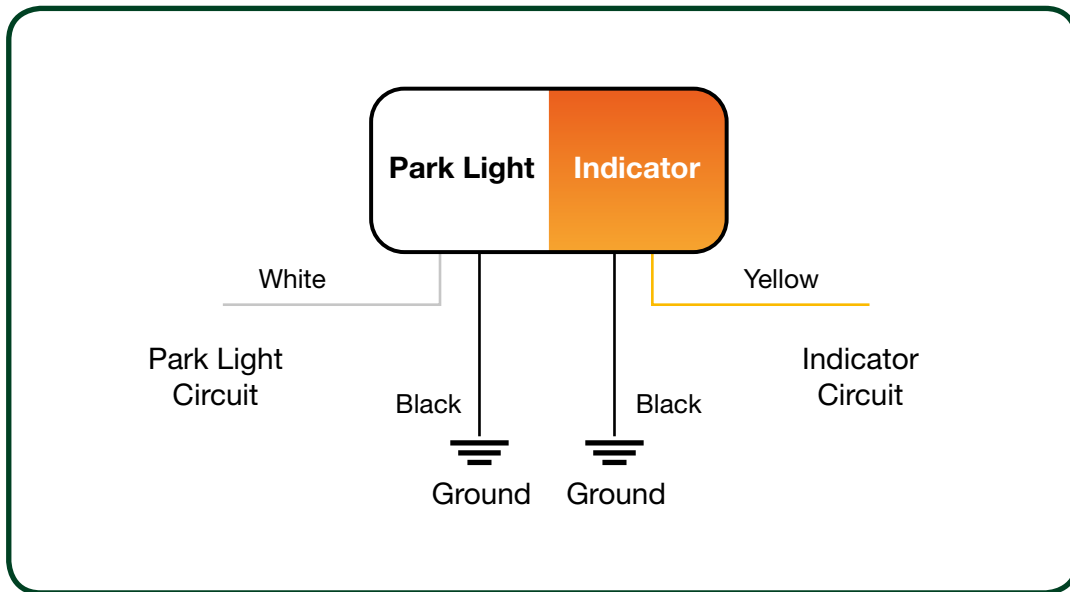

FOG LIGHTS

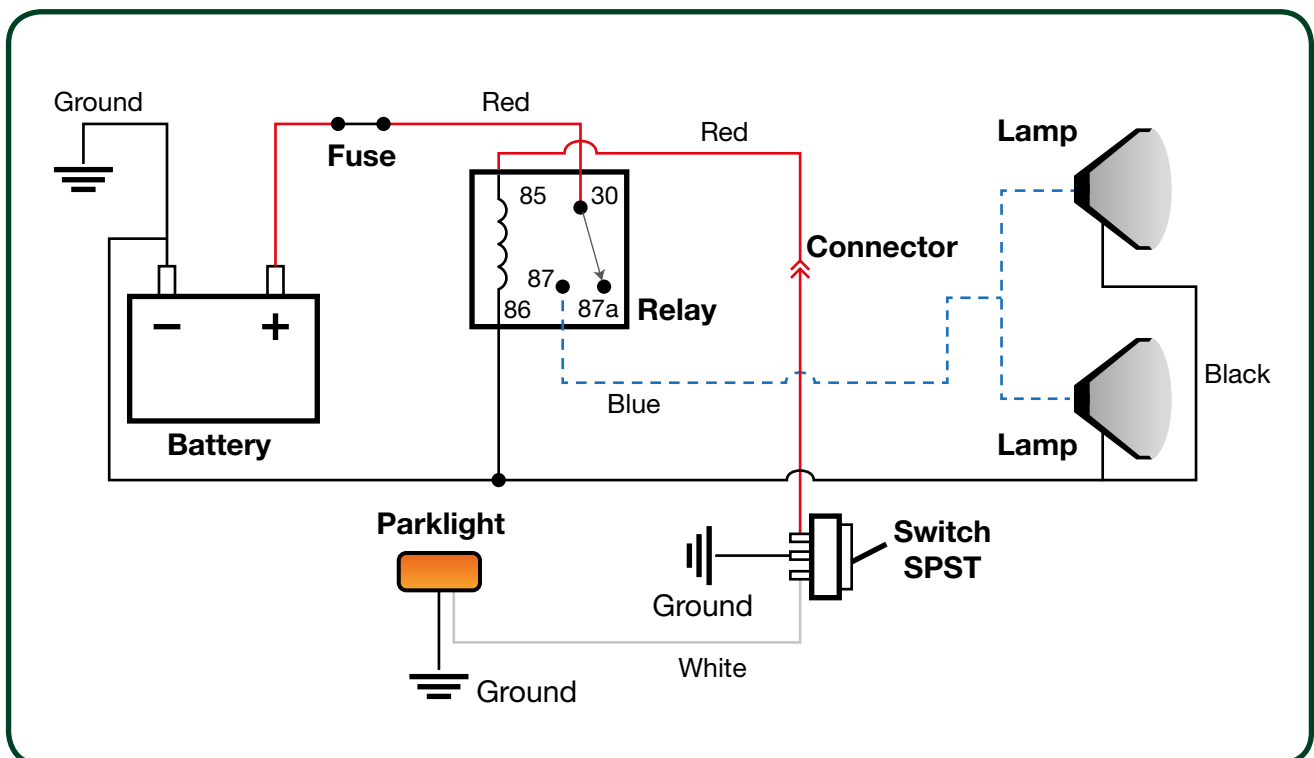

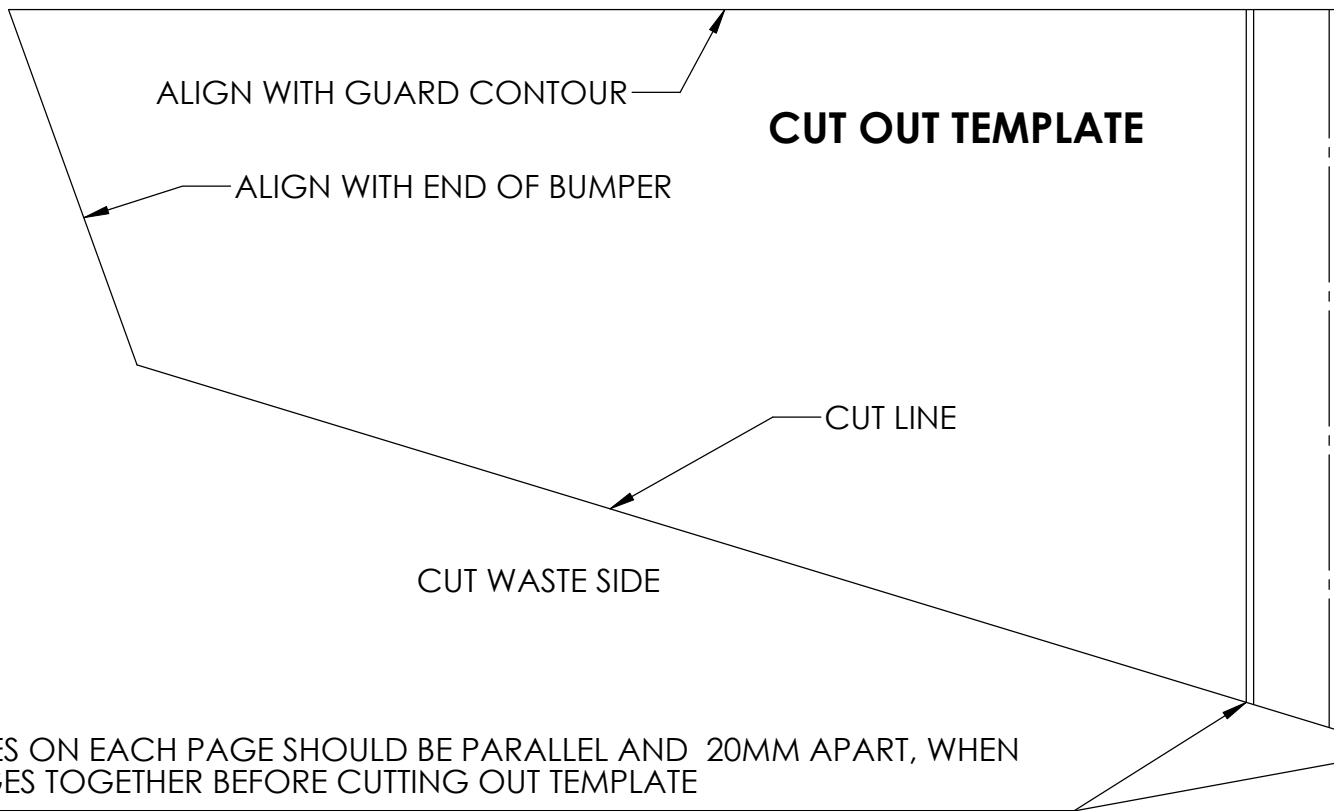

TOYOTA PRADO 150 IRONMAN BULLBAR CUT TEMPLATE

*Be sure to disable page scaling, when printing.

- 1) BUTT PAGES TOGETHER, CHECK THAT DOUBLE LINES ARE PARALLEL AND 20mm APART.
- 2) TAPE PAGES TOGETHER AND CUT OUT PAPER TEMPLATE.
- 3) ALIGN TEMPLATE AS SHOWN ON VEHICLE AND CUT BUMPER WHERE INDICATED.

CUT OUT TEMPLATE

TO FRONT OF VEHICLE
↓

**IRONMAN 4X4
CNR CENTRE AND WESTALL RD
CLAYTON VIC AUSTRALIA 3168**

**+61 3 9532 1111
1300 731 137**

www.ironman4x4.com

CUT WASTE SIDE

CUT LINE
←