



INSTALLATION GUIDE

BBT012/ BBC012/ BBCD012

NISSAN NAVARA D40 & PATHFINDER R51

2WD & 4WD Models



- Ironman 4x4 BBT/ BBC/ BBCD012 Bull Bars fit to a Nissan Navara D40 & Pathfinder R51.
Does not fit 2011 onwards Spain Built vehicles.
- It will take about 4 hours to install.

NOTE: This product has been tested for air bag compatibility and therefore the mounting system MUST NOT be modified

IMPORTANT: Bull Bar installations should only be done by a qualified person and it is the responsibility of this person to ensure correct fitment.

1. Before installation check bull bar application is compatible with your vehicle.

2. Remove all mounting hardware holding lower section of front bumper bar to vehicle.

3. Mask above recess line across bumper bar to protect against damage whilst cutting.

NOTE: If your bumper bar does not have the line shown, the bull bar will NOT fit your vehicle.



4. Cut along line and remove lower section of bumper.



5. Trim plastic bumper bar reinforcement level with bumper cut.

6. Place cutting template onto end of bumper as shown as mark cut line.

NOTE: The cutting template is located on the last two pages of this installation guide, Pages 12 & 13.



7. Cut along line marked and repeat on other side of vehicle.



8. Install pinch weld to cuts on ends of bumper bar.



9. Trim guard liners along line as shown and remove square section adjacent to edge of bumper as shown.



10. Remove steel bumper bar reinforcement.

Depending of type of vehicle chassis install chassis brackets as follows:

SPAIN BUILD

11. Remove lower captive nut from front of chassis by refitting factory bolt loosely and hitting with a hammer to break welds.



12. Using nut plate supplied as a guide mark centre mounting hole for bracket, centre punch and drill to 7.5mm.



13. Insert nut plate into front of chassis and attach mounting bracket using M12 bolts, spring washers and flat washers provided.



Refer to Step 15 to continue.

Depending of type of vehicle chassis install chassis brackets as follows:

THAI BUILD

14. Attach mounting bracket to plate on front of chassis into factory captive nuts using M12 bolts, spring washers and flat washers provided.



ALL MODELS

15. Attach strengthening brackets to rear of chassis brackets inside and outside of chassis using M12 bolts, spring washers, flat washers and nuts provided.

Push firmly against chassis and tighten all bolts.



16. Using holes in strengthening brackets as a guide drill two horizontal holes through chassis and secure using M10 x 100mm bolts, flat washers, crush tubes, spring washers and nuts.



17. Fit winch mounting cradle between chassis brackets using M12 hardware, align rear protection plate mounting points with front holes of factory protection plate and tighten all bolts.



18. If winch is being installed, refer to winch installation instructions, Pages 7 - 10.
19. Unwrap bull bar. Check over riders and light assemblies are tight in bull bar before installation.
20. Fit bull bar to chassis brackets using M12 bolts, flat washers, spring washers and nuts provided.
21. Align bull bar with vehicle and tighten all bolts.

22. Once bar is aligned with vehicle and tightened drill through pinning holes between bull bar and chassis bracket and secure with bolts, washers and nuts provided.

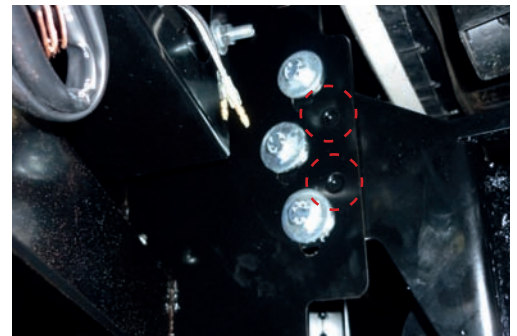

23. Connect park lights, indicators and fog lights as per wiring diagrams at the back of fitting instruction manual.
24. Fit protection plates to underneath of bull bar using M8 bolts, spring washers and flat washers provided.

Winch Installation

IMPORTANT: Before winch is installed to winch cradle, the clutch handle will need to be rotated to a more convenient position for access through bull bar.

1. Stand winch vertically on motor with gearbox facing upwards.



2. Undo and remove 2 chrome Allen head bolts which hold the gearbox to the tie rods.



3. Lift gearbox off winch.



NOTE: If shaft comes out of cable drum remove it from the gearbox and place it back into the drum making sure it engages with the brake.



NOTE: Also make sure that the drum support bush remains in the end of the drum support housing with the locating tang in the correct position.



4. Undo and remove 10 Allen head bolts that hold the gearbox housing to the drum support housing and rotate the drum support housing to the desired location.

For most Ironman 4X4 bull bars the gearbox will need to be rotated 2 holes in an anti clockwise direction. Make sure the gearbox gasket does not tear.



5. Re-install 10 bolts and tighten firmly.
NOTE: Take care not to over-tighten.



6. Refit gearbox to winch, refit and tighten Allen head bolts into tie rods.



7. Bolt winch to cradle with gearbox to the left hand side of vehicle and cable spooling from bottom of the cable drum using bolts and washers provided.

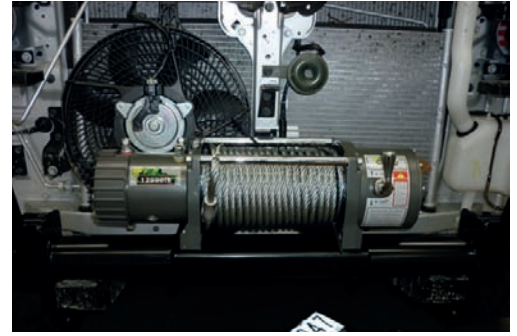

8. Bolt roller fairlead to recess in front of bull bar using bolts, washers and nuts provided.



9. Fit bull bar to vehicle referring to steps 19 - 24 of bull bar fitting instructions.

10. If winch control box is being fitted to top of bull bar remove control box bracket from control box.

11. Place control box on top of centre pan of bull bar with socket for hand controller facing outwards from vehicle. Mark position of the four mounting bolts.

Drill four holes to 6.5mm. Rust proof and de burr and attach control box to bar.



12. Connect three colour coded cables to the corresponding poles on winch motor.



13. Connect the thin black earth wire and negative battery cable to the earth connection on the opposite side of winch motor.



14. Run the positive and negative battery cables into the engine bay taking care to secure cables away from any sharp or moving objects.

Connect negative battery cable to the main battery.

15. Find a convenient location close to main battery to mount battery isolation switch.

Connect positive battery cable to one side of isolation switch and connect other side to the positive battery terminal of main battery.



Wiring Diagrams

PARK LIGHT & INDICATOR

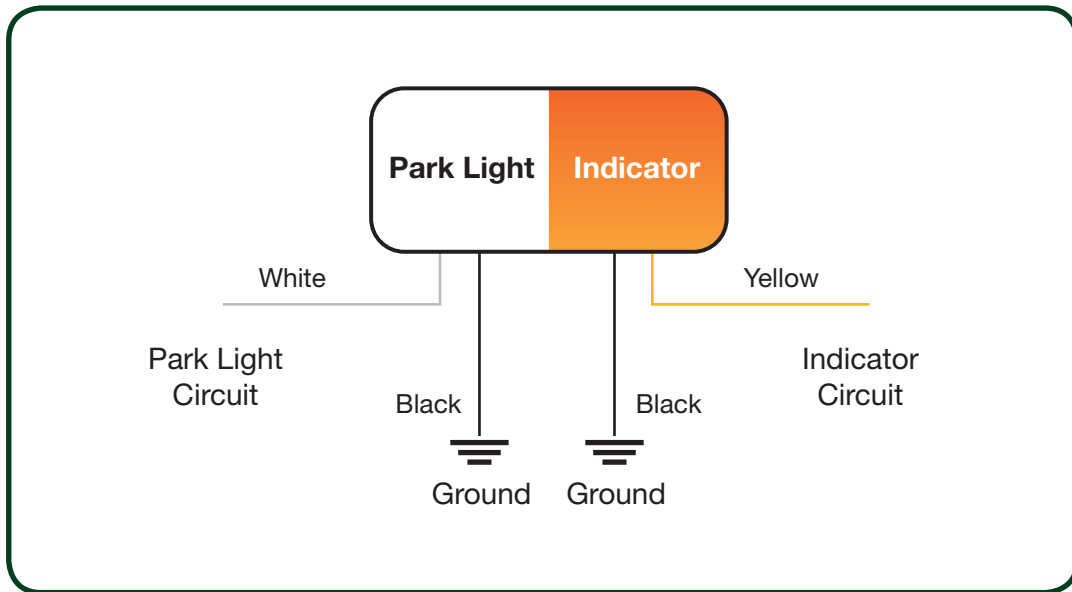

FOG LIGHTS

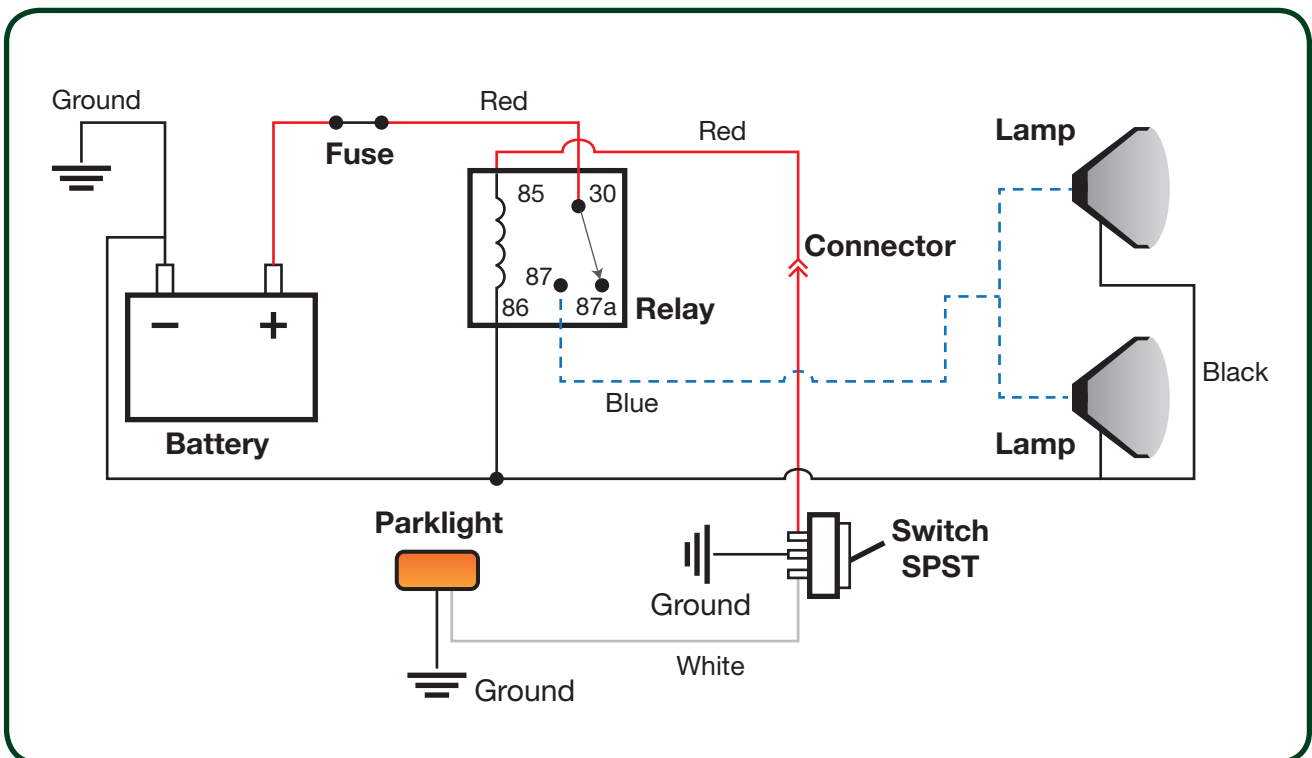

NISSAN NAVARA D40 IRONMAN BULLBAR CUT TEMPLATE

LEFT PAGE 1/2

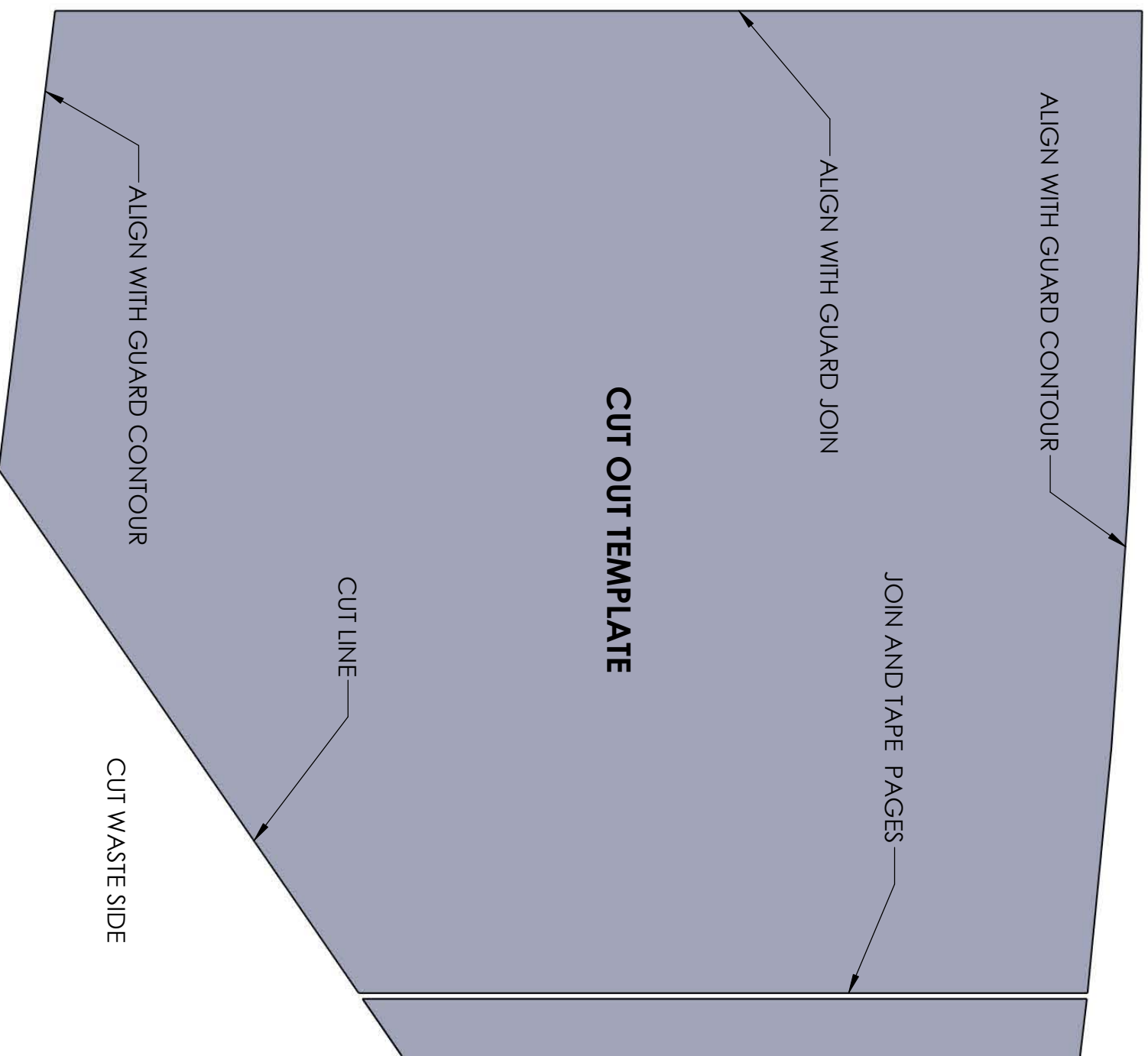

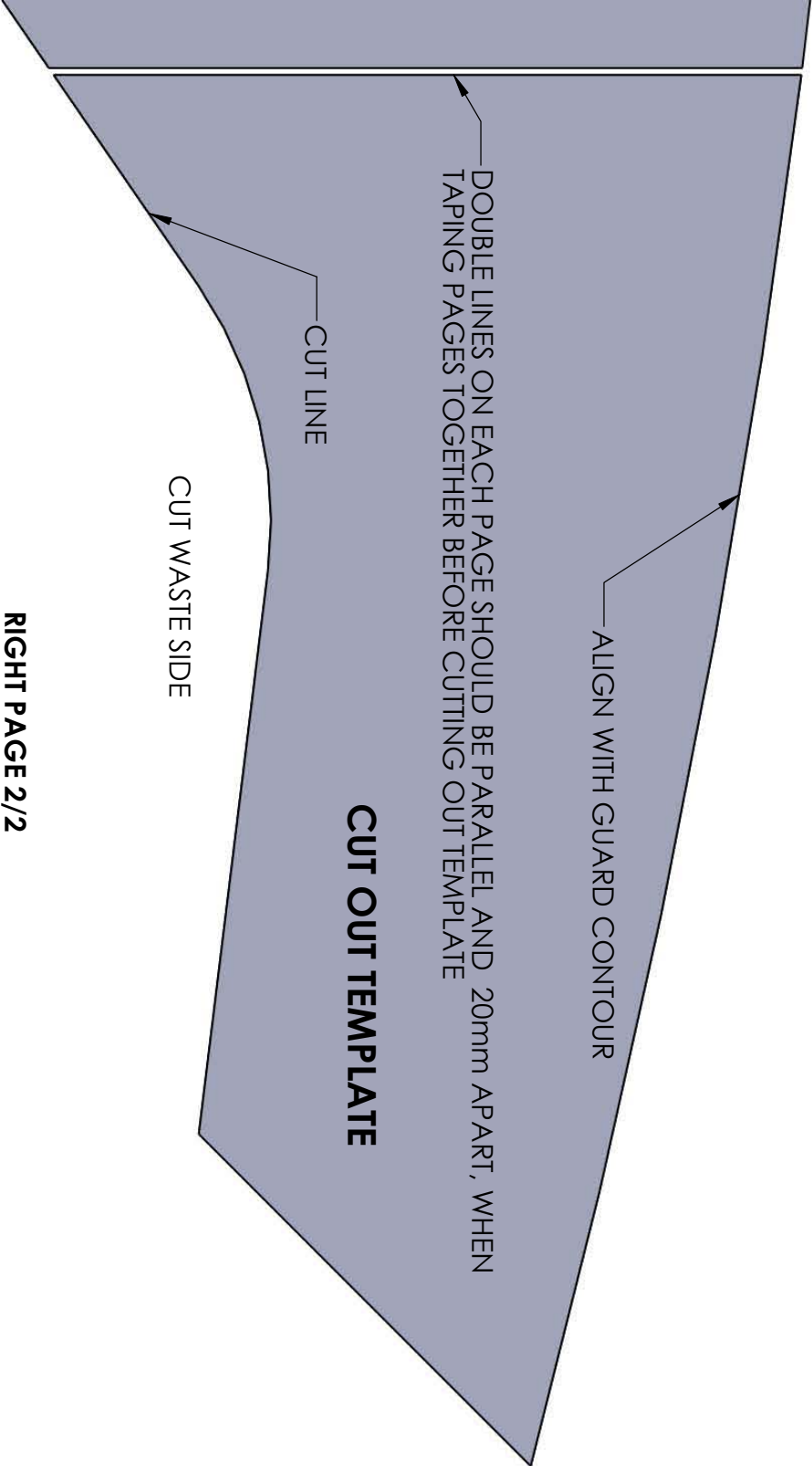

ALIGN WITH GUARD CONTOUR

DOUBLE LINES ON EACH PAGE SHOULD BE PARALLEL AND 20mm APART, WHEN TAPING PAGES TOGETHER BEFORE CUTTING OUT TEMPLATE

CUT LINE

CUT WASTE SIDE

CUT OUT TEMPLATE

RIGHT PAGE 2/2