

YAKIMA **BigStack**

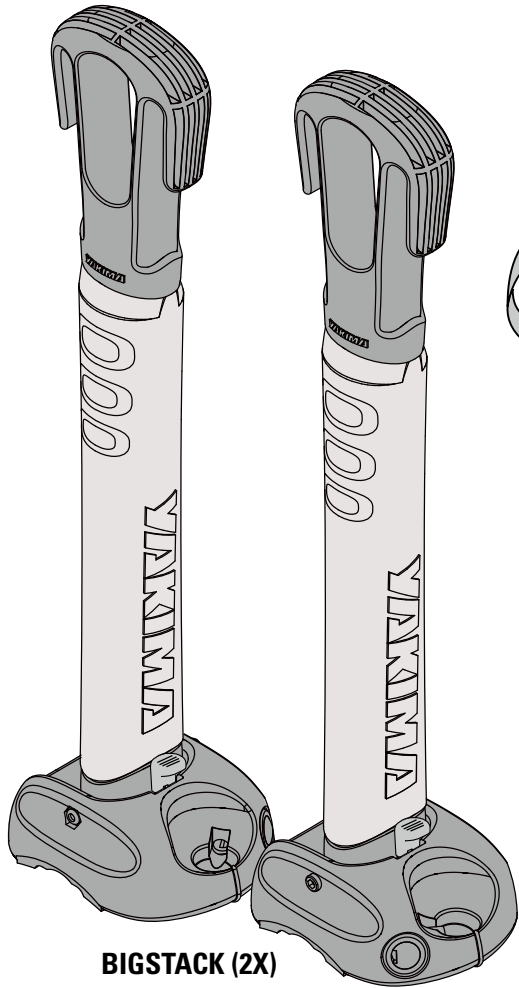

MINIMUM CROSSBAR SPREAD 24"

FOR FACTORY RACKS: Check fitlist notes, or Yakima.com for your vehicle's crossbar spread.



BIGSTACK (2X)

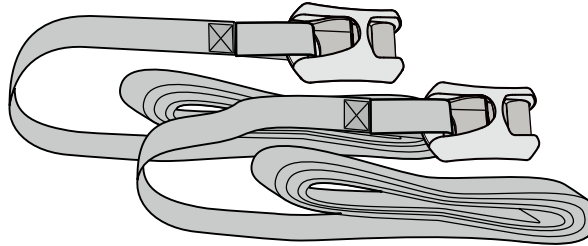

HEAVY DUTY STRAP (2X)

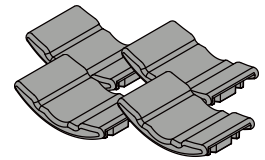

PAD (4X)

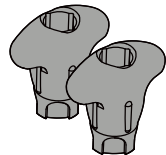

**ADJUSTMENT
KNOB (2X)**

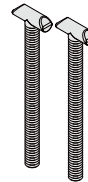

T-BOLT (2X)

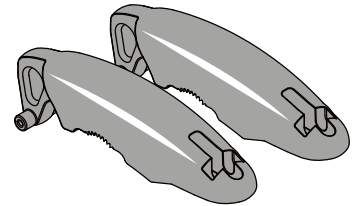

BAIL (2X)

BOW STERN TIE DOWN

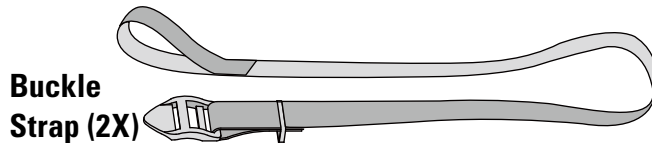

**Buckle
Strap (2X)**

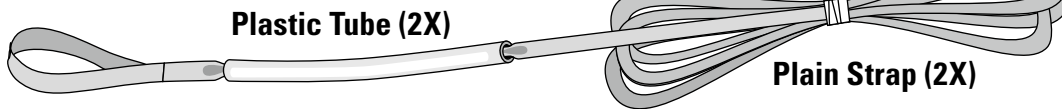

Plastic Tube (2X)

Steel Hook (2X)

Plain Strap (2X)



IMPORTANT WARNING

IT IS CRITICAL THAT ALL YAKIMA RACKS AND ACCESSORIES BE PROPERLY AND SECURELY ATTACHED TO YOUR VEHICLE. IMPROPER ATTACHMENT COULD RESULT IN AN AUTOMOBILE ACCIDENT, AND COULD CAUSE SERIOUS BODILY INJURY OR DEATH TO YOU OR TO OTHERS. YOU ARE RESPONSIBLE FOR SECURING THE RACKS AND ACCESSORIES TO YOUR CAR, CHECKING THE ATTACHMENTS PRIOR TO USE, AND PERIODICALLY INSPECTING THE PRODUCTS FOR ADJUSTMENT, WEAR, AND DAMAGE. THEREFORE, YOU MUST READ AND UNDERSTAND ALL OF THE INSTRUCTIONS AND CAUTIONS SUPPLIED WITH YOUR YAKIMA PRODUCT PRIOR TO INSTALLATION OR USE. IF YOU DO NOT UNDERSTAND ALL OF THE INSTRUCTIONS AND CAUTIONS, OR IF YOU HAVE NO MECHANICAL EXPERIENCE AND ARE NOT THOROUGHLY FAMILIAR WITH THE INSTALLATION PROCEDURES, YOU SHOULD HAVE THE PRODUCT INSTALLED BY A PROFESSIONAL INSTALLER.

PREPARE FOR INSTALLATION

- 1** Rotate the BigStack to its upright position. It will lock into place.

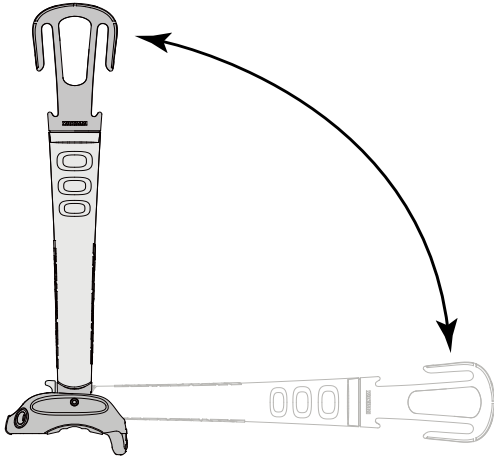

NOTE: Use the red release button on the base when you wish to fold the mast down.

- 2** Install both pads.

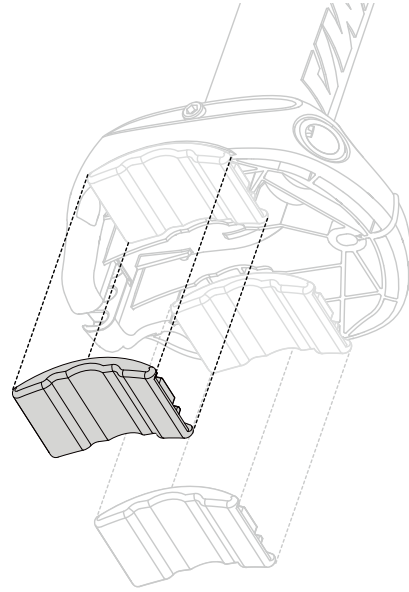

- 3** Insert t-bolt through BigStack base and adjustment knob.

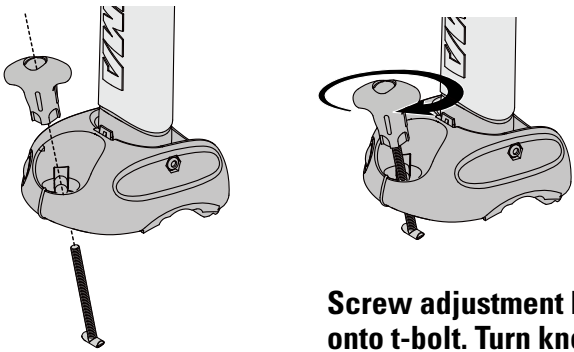

Screw adjustment knob onto t-bolt. Turn knob three full turns.

- 4** Determine position of BigStack on the crossbar before proceeding to step 5.

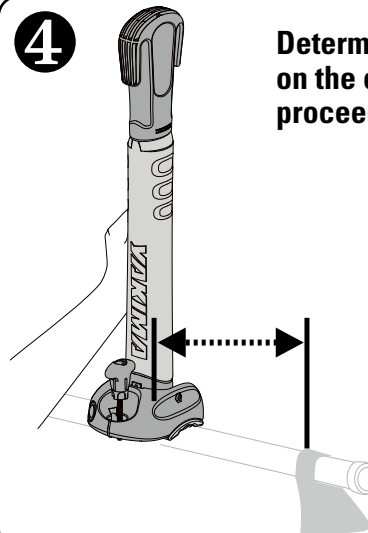

Distance from the BigStack to the tower should equal the width of your kayak (or kayaks) on edge.

INSTALL BIGSTACK ON CROSSBARS

- 5** **ROUND BAR ONLY**

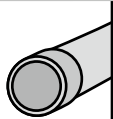

Snap bail to base, around crossbar.

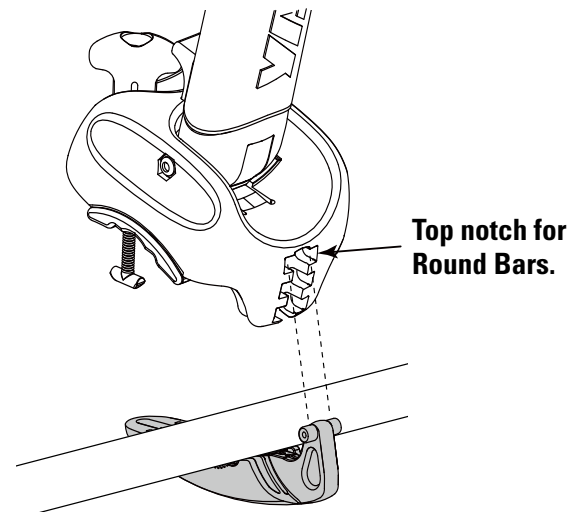

5 SQUARE BAR ONLY

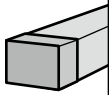

Snap bail to base, around crossbar.

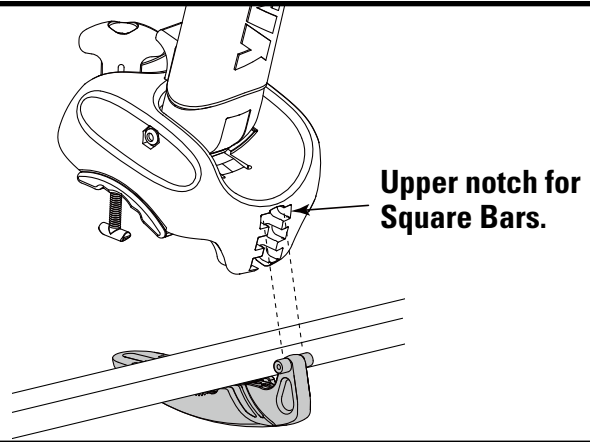

5 FACTORY BAR ONLY

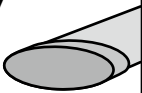

Snap bail to base, around crossbar.

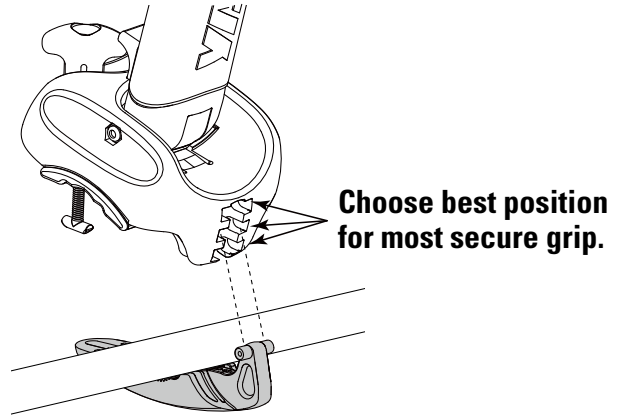

6 Insert t-bolt through bail.

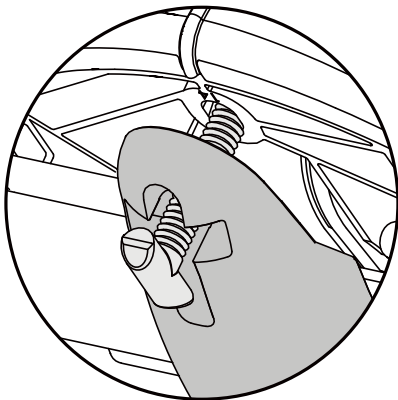

Rotate t-bolt.

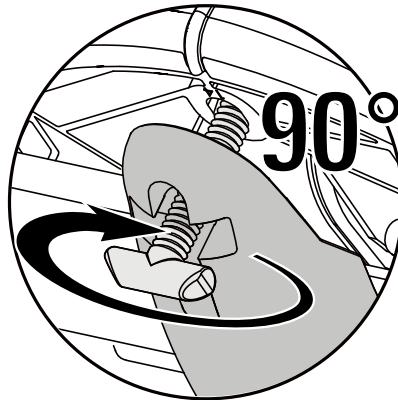

7 NOW COMPLETELY TIGHTEN THE BIGSTACK USING FIRM PRESSURE.

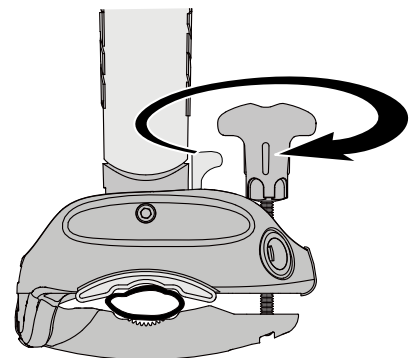

8 INSTALL SECOND BIGSTACK

Repeat Steps 1 through 7 to install second BigStack.

Install BigStacks so that the lock housings face same side of vehicle.

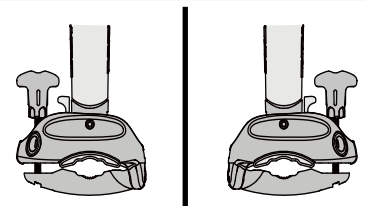

Install BigStacks so that they are offset and fold toward each other.

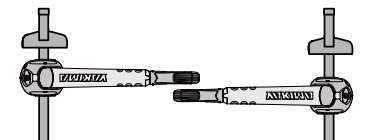



CAUTION: BigStacks may require re-positioning to avoid vehicle contact.

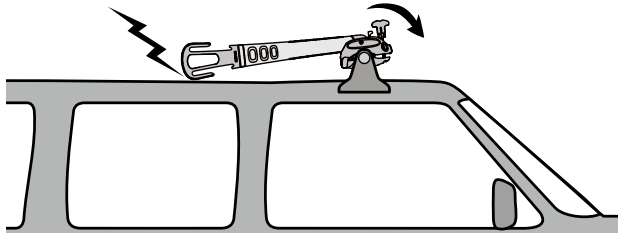

CAUTION: BigStacks may need to be adjusted to be offset to allow for folding masts down when not in use.

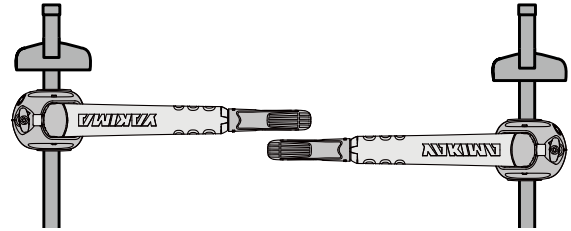

GET READY TO LOAD YOUR BOAT(S)

NOT RECOMMENDED

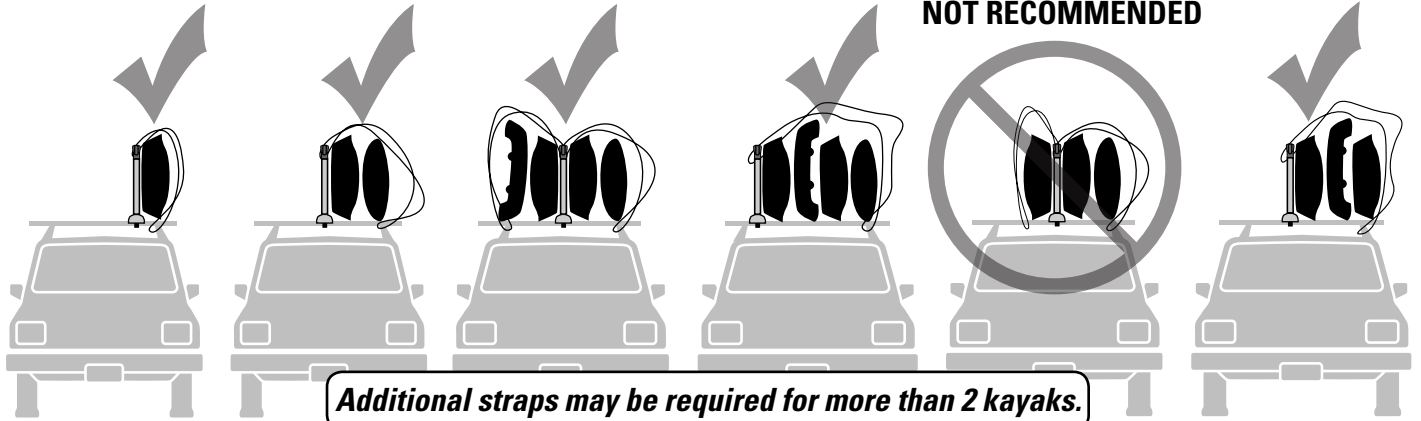

FOLLOW THESE FOUR RULES WHEN STRAPPING KAYAK(S):

1

Distance of BigStack from crossbar tower is exactly the width of kayak(s) on edge.

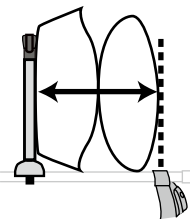

2

Loop strap under crossbar at least once.

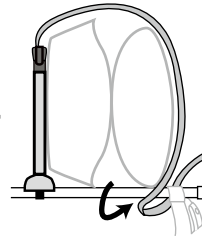

3

Loop strap inboard of crossbar tower.

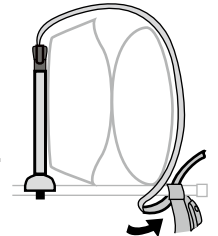

4 Always tie down the bow and stern. See step 12 for proper bow stern tie down procedure.

9 LOAD THE BOAT— TIE IT DOWN WITH STRAPS

TO LOAD STRAP WITH BIGSTACK IN DOWN POSITION:

Pass strap through hole.

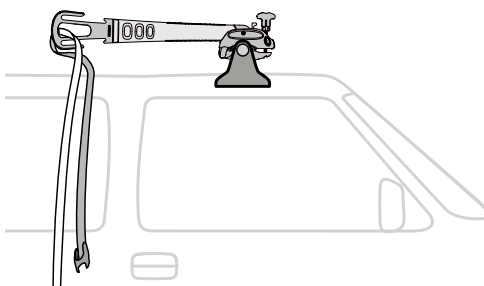

Raise mast to upright position.

Continue tying boats as shown on following pages.

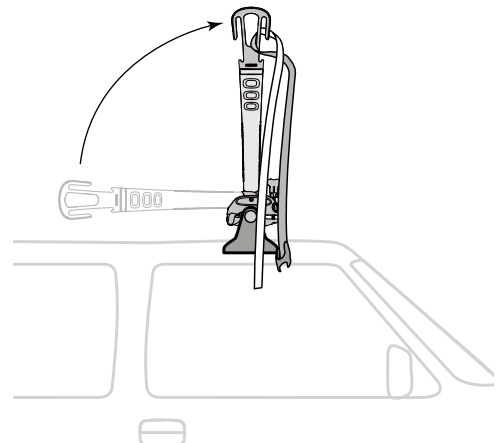

CONTINUE TO LOAD THE BOAT— TIE IT DOWN WITH STRAPS

TO LOAD STRAP WITH BIGSTACK IN UPRIGHT POSITION:

LOOP STRAP AROUND BIGSTACK POST.

Cross lines and set aside.

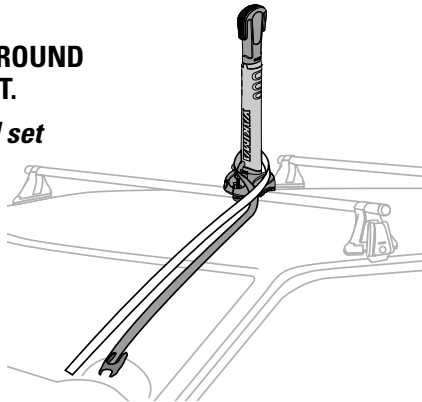

LOAD BOAT.

- Bring straps up and over boat.
- Hang to the side.

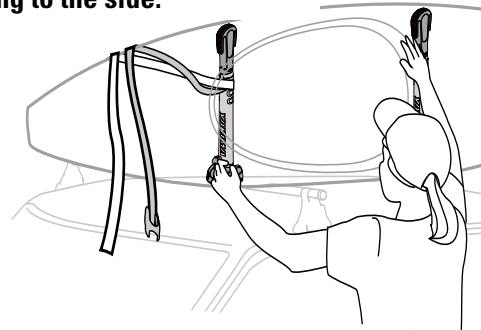

- Hook the strap at the top of the BigStack.
- Slide buckle up so that it hangs at top edge of boat.

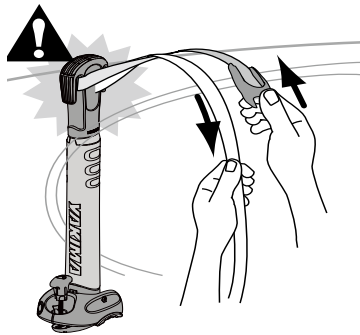

ADDED SECURITY:

- Pass strap inboard under crossbar.
- Pass strap under boat around base of BigStack.
- Pass under crossbar again and attach to buckle.

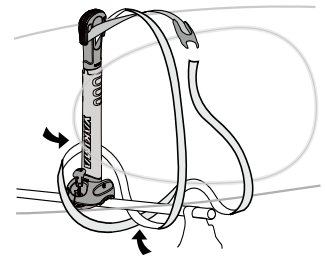

NOTE: Straps are to be inside of towers. If straps are to be outside of tower due to tower/bar position, use *STRAP CAPS* (Yakima part number 8005015) to prevent straps from sliding off the end of the crossbars.

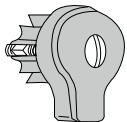

Yakima part number 8005015
(sold separately).

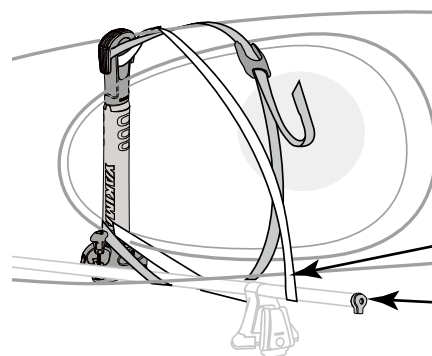

Strap outside of tower.

Use Strap Cap.

10

CONNECT AND TIGHTEN

- Insert end of strap into buckle as shown.

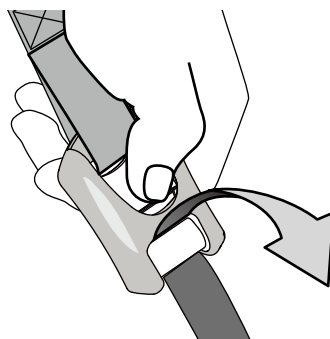

TIGHTEN STRAPS:

- To tighten straps, hold and pull.
- Secure extra strap.

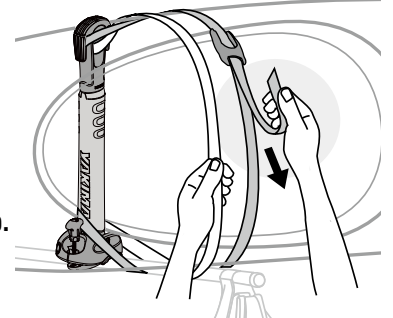

11 INSTALL SKS LOCKS ACCORDING TO LOCK INSTRUCTIONS

(Purchased separately).

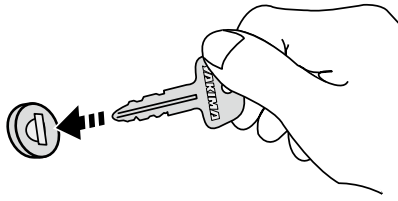

Lines on adjustment knob and BigStack base must be aligned to lock.

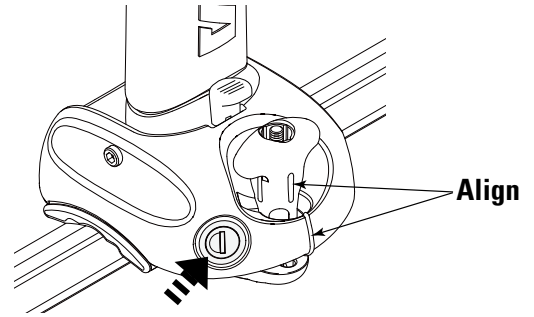

BOW STERN TIE DOWN ATTACHMENT

12 Attach buckle strap to boat.

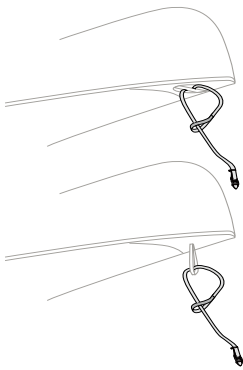

Attach strap to *grab handle or rescue bar* and pull tight.

13 Attach hook to plain strap loop.

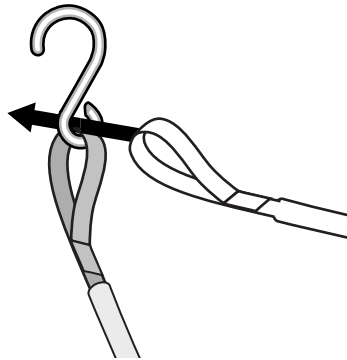

14 Hook the strap to a metal surface on the bumper, tow loop, or frame hole using hook.

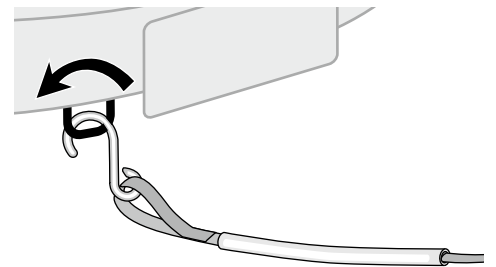

15 Slide plastic tube to protect vehicle at contact point.

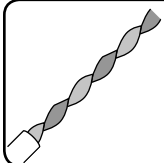

NOTE: Twisting the strap will help reduce wind vibration.

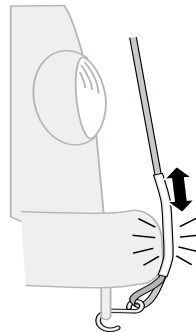

16 Insert end of plain strap into buckle.

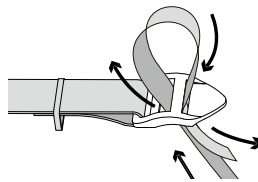

17 Adjust strap tension by pulling plain end.

- Apply even pressure to front and rear straps.
- Bind up and tie off any excess strap.

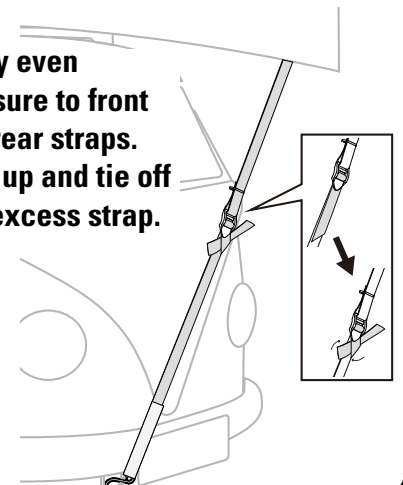

Failure to secure front and rear of long loads to ends of vehicle can result in property damage, personal injury, or death.



Check straps periodically during travel and tighten if necessary. Replace any straps that are worn or frayed before using (see your Yakima dealer).



BEFORE DRIVING AWAY

- Test movement by rocking boat.
- Tighten again if loose.
- **READ ALL CAUTIONS AND LIMITS.**

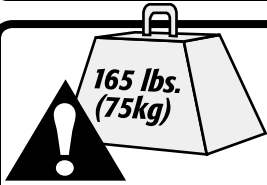

WEIGHT LIMITS

Follow the YAKIMA Fit List or check online at Yakima.com for your rack's weight limit. Do not exceed the weight limit of your vehicle's racks.

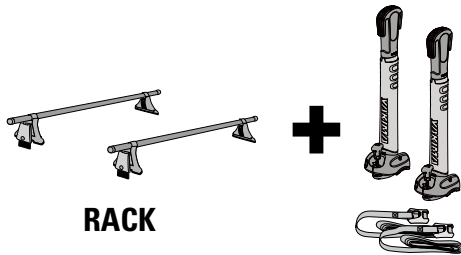

RACK

+

+

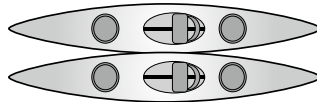

LOAD

=

Not more than 165 lbs. (75 kg) unless otherwise noted.

THIS PRODUCT (7 lbs. / 3.2 kg)

**(Some vehicles will be rated lower than 165 lbs. (75 kg))*

IF YOU REMOVE YOUR CARRIER, FOLLOW INSTRUCTIONS TO INSTALL AGAIN.

Follow safety checks in accessory instructions before every installation.

REAR HATCH

Some longer loads may prevent the rear hatch from fully opening.

ALWAYS USE CAUTION WHEN OPENING YOUR HATCH.

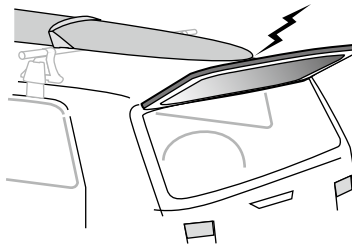

ANTENNA

Antenna on the roof may need to be removed to prevent interference with long loads.



WARNING: BE SURE ALL HARDWARE IS SECURED ACCORDING TO INSTRUCTIONS. ATTACHMENT HARDWARE CAN LOOSEN OVER TIME. CHECK BEFORE EACH USE, AND TIGHTEN IF NECESSARY.

MAINTENANCE: Use non-water soluble lubricant on screws. Use a soft cloth with water and mild detergent to clean plastic parts.

REMOVE ACCESSORY BEFORE ENTERING AN AUTOMATIC CAR WASH.

TECHNICAL ASSISTANCE OR REPLACEMENT PARTS
Contact your dealer, or visit www.yakima.com, or call (888)925-4621
Monday through Friday, 7:00 AM to 5:00 PM, PST



This product is covered by YAKIMA's "Love It Till You Leave It" Limited Lifetime Warranty
To obtain a copy of this warranty, go online to www.yakima.com or email us at yakwarranty@yakima.com or call (888) 925-4621

KEEP THESE INSTRUCTIONS!

DISTANCE MINIMALE ENTRE LES BARRES TRANSVERSALES : 61 CM (24 PO)

POUR LES PORTE-BAGAGES D'ORIGINE : vérifier dans les notes de la liste de compatibilité ("Fit list") ou consulter le site yakima.com pour connaître la distance entre les barres transversales s'appliquant au véhicule.

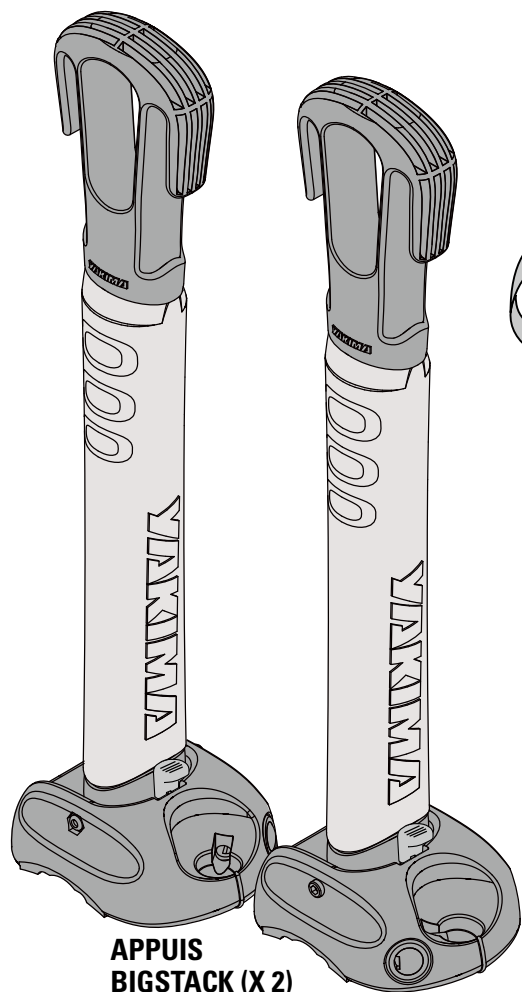

APPUIS
BIGSTACK (X 2)

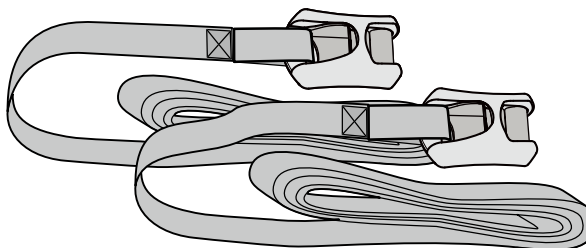

SANGLES RÉSISTANTES (X 2)

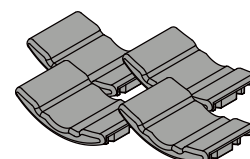
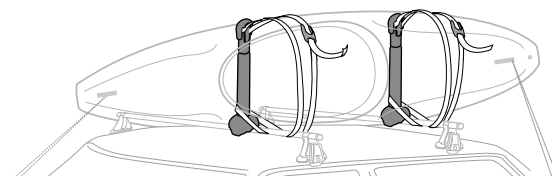

PATINS (X 4)

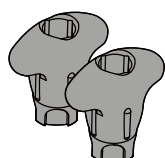

BOUTONS DE
SERRAGE (X 2)



BOULONS EN T (X 2)

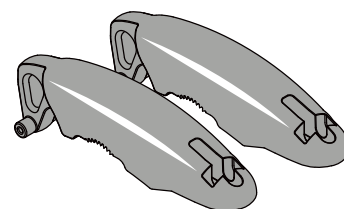

MÂCHOIRES (X 2)

SANGLES D'ARRIMAGE AVANT/ARRIÈRE

Sangles avec
boucle (x 2)

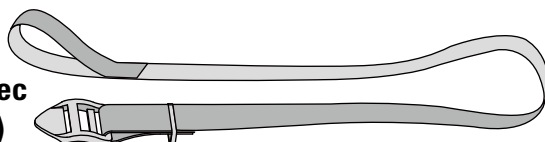

Manchons en plastique (x 2)

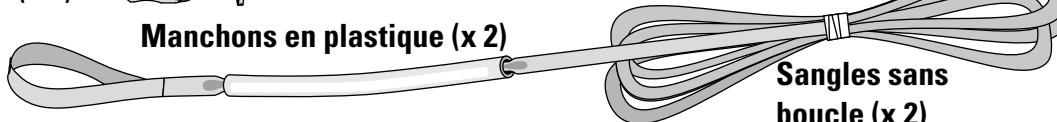

Sangles sans
boucle (x 2)

Crochets en
acier (x 2)



AVERTISSEMENT IMPORTANT:

IL EST IMPÉRATIF QUE LES PORTE-BAGAGES ET LES ACCESSOIRES YAKIMA SOIENT CORRECTEMENT ET SOLIDEMENT FIXÉS AU VÉHICULE. UN MONTAGE MAL RÉALISÉ POURRAIT PROVOQUER UN ACCIDENT D'AUTOMOBILE, QUI POURRAIT ENTRAÎNER DES BLESSURES GRAVES OU MÊME LA MORT, À VOUS OU À D'AUTRES PERSONNES. VOUS ÊTES RESPONSABLE DE L'INSTALLATION DU PORTE-BAGAGES ET DES ACCESSOIRES SUR VOTRE VÉHICULE, D'EN VÉRIFIER LA SOLIDITÉ AVANT DE PRENDRE LA ROUTE ET DE LES INSPECTER RÉGULIÈREMENT POUR EN CONTRÔLER L'ÉTAT, L'AJUSTEMENT ET L'USURE. VOUS DEVEZ DONC LIRE ATTENTIVEMENT TOUTES LES INSTRUCTIONS ET TOUS LES AVERTISSEMENTS ACCOMPAGNANT VOTRE PRODUIT YAKIMA AVANT DE L'INSTALLER ET DE L'UTILISER. SI VOUS NE COMPRENEZ PAS TOUTES LES INSTRUCTIONS ET TOUS LES AVERTISSEMENTS, OU SI VOUS N'AVEZ PAS DE COMPÉTENCES EN MÉCANIQUE ET NE COMPRENEZ PAS PARFAITEMENT LA MÉTHODE DE MONTAGE, VOUS DEVRIEZ FAIRE INSTALLER LE PRODUIT PAR UN PROFESSIONNEL.

PRÉPARER LE MONTAGE

- 1** Faire pivoter l'appui en position relevée : il se verrouillera en place.

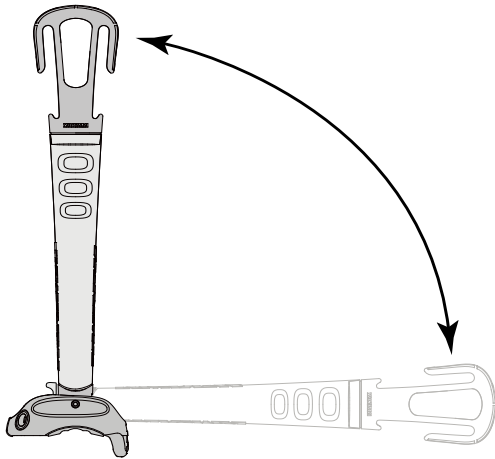

REMARQUE : le bouton rouge de la base permet de rabattre l'appui.

- 2** Poser les deux patins.

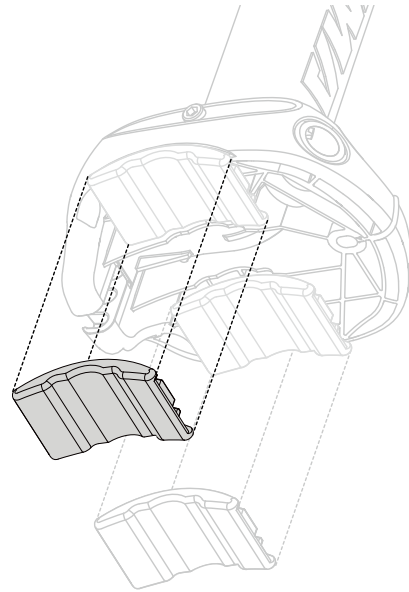

- 3** Enfiler le bouon en T à travers la base de l'appui.

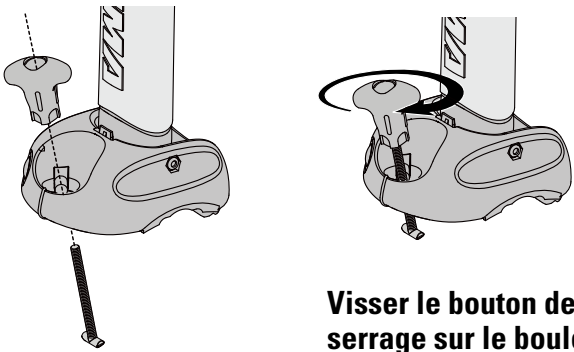

Visser le bouton de serrage sur le boulon en donnant trois tours.

- 4** Déterminer la position des appuis sur les barres transversales avant de passer à l'opération 5.

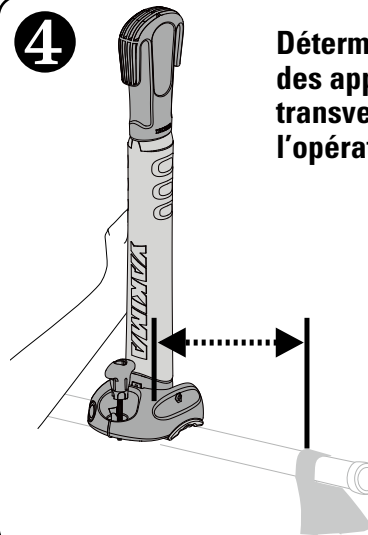

La distance entre l'appui et le pied doit correspondre environ à l'épaisseur du (des) kayak(s) à transporter sur la tranche.

POSER LES APPUIS SUR LES BARRES TRANSVERSALES

- 5** BARRES RONDES SEULEMENT

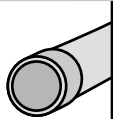

Emboîter la mâchoire dans la base, sur la barre.

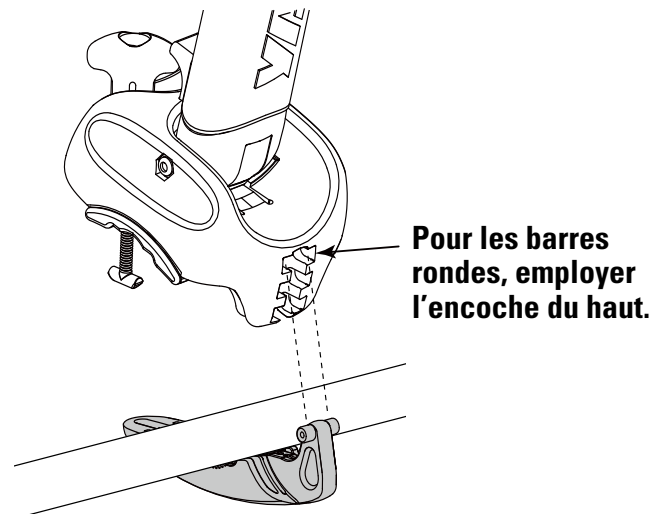

Pour les barres rondes, employer l'encoche du haut.

5 BARRES
CARRÉES
SEULEMENT

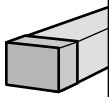

Emboîter la mâchoire dans
la base, sur la barre.

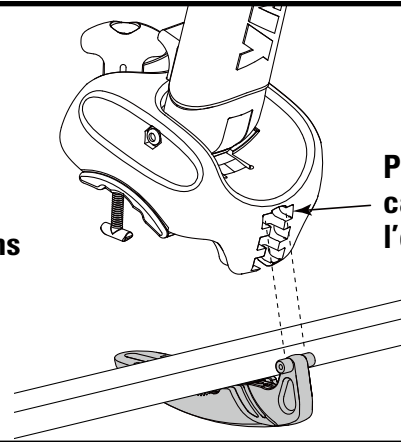

Pour les barres
carrées, employer
l'encoche du haut.

5 BARRES
D'ORIGINE
SEULEMENT

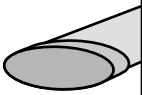

Choisir l'encoche
offrant le montage
le plus solide.

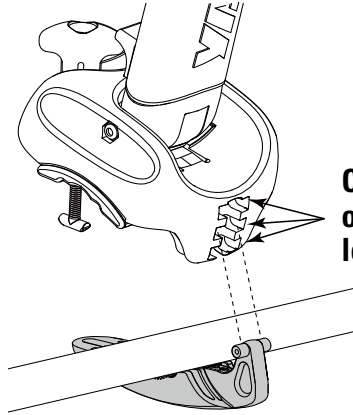

6 Enfiler le boulon en T
à travers la mâchoire.

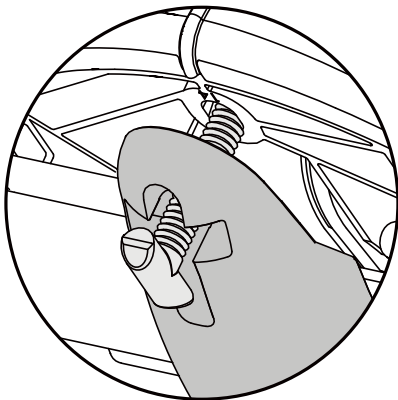

Faire pivoter le boulon en T.

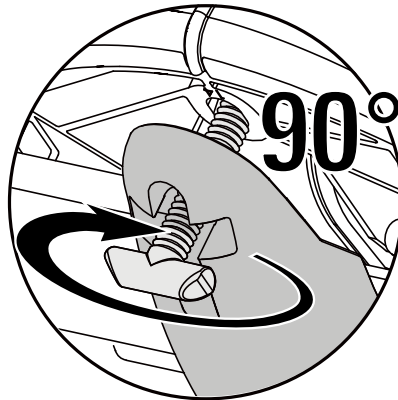

7 SERRER MAINTENANT
L'APPUI COMPLÈTEMENT
EN APPLIQUANT UNE
PRESSION FERME.

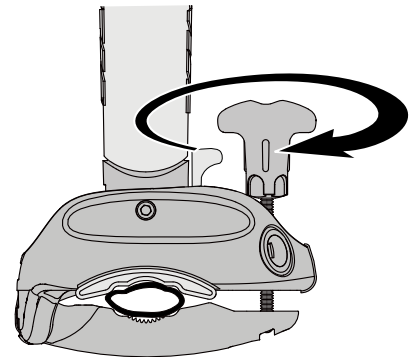

8 POSER LE DEUXIÈME APPUI

Répéter les opérations 1 à 7.

Poser les appuis de manière que les
logements de serrure soient tournés
du même côté du véhicule.

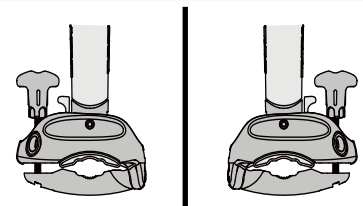

Poser les appuis de manière qu'ils
soient décalés et se rabattent l'un
vers l'autre.

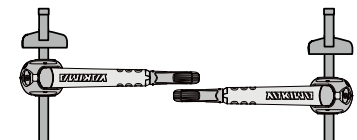



ATTENTION : il faudra peut-être repositionner les appuis pour qu'ils ne viennent pas porter contre le véhicule.

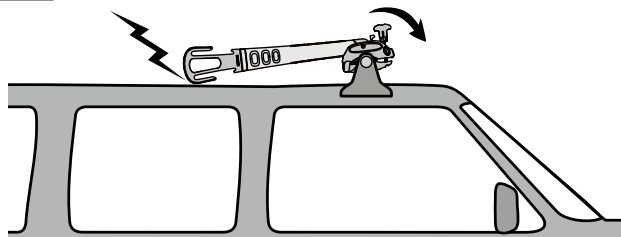

ATTENTION : il faudra peut-être décaler les appuis pour que l'on puisse les rabattre quand ils ne servent pas.

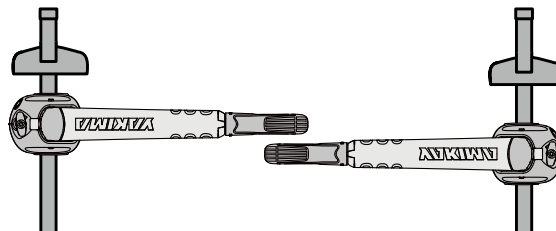

SE PRÉPARER À CHARGER LA (LES) EMBARCATION(S)

NON RECOMMANDÉ

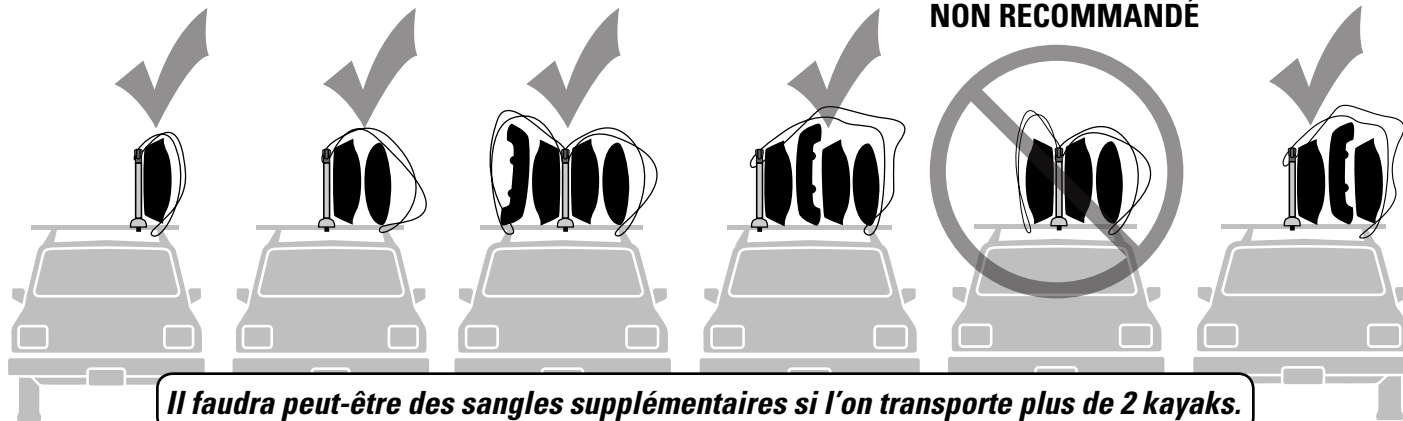

Il faudra peut-être des sangles supplémentaires si l'on transporte plus de 2 kayaks.

POUR ARRIMER LES KAYAKS, SUIVRE CES QUATRE RÈGLES :

1

La distance entre l'appui et le pied des barres doit correspondre à l'épaisseur du (des) kayak(s) à transporter sur la tranche.

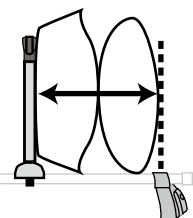

2

Faire passer la sangle sous la barre transversale au moins une fois.

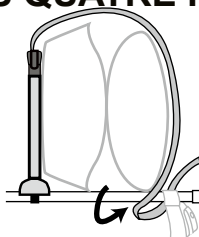

3

Passer les sangles à l'intérieur des pieds.

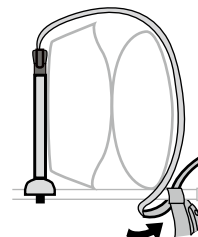

4

Toujours arrimer l'avant et l'arrière de l'embarcation. On explique comment à l'opération 12.

9 CHARGER L'EMBARCATION ET L'ARRIMER AVEC LES SANGLES

POUR PLACER LA SANGLE QUAND L'APPUI EST RABATTU :

Enfiler la sangle à travers le trou.

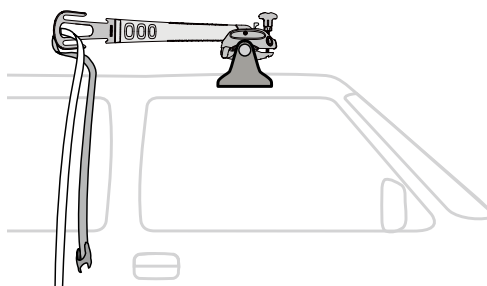

Redresser l'appui à la verticale.

Poursuivre le chargement tel qu'expliqué aux pages suivantes.

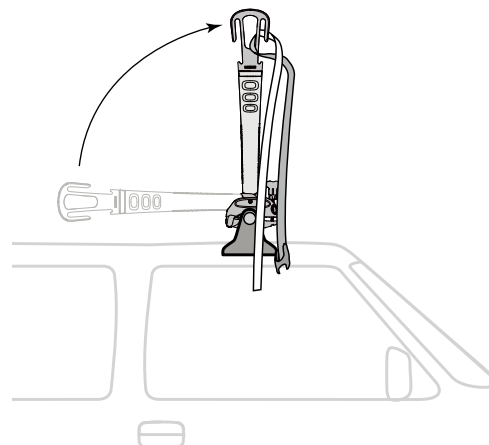

CHARGER L'EMBARCATION ET L'ARRIMER AVEC LES SANGLES (SUITE)

POUR PLACER LA SANGLE QUAND L'APPUI EST RELEVÉ :

PASSER LA SANGLE AUTOUR DE L'APPUI.

Croiser les deux brins et les mettre sur le côté.

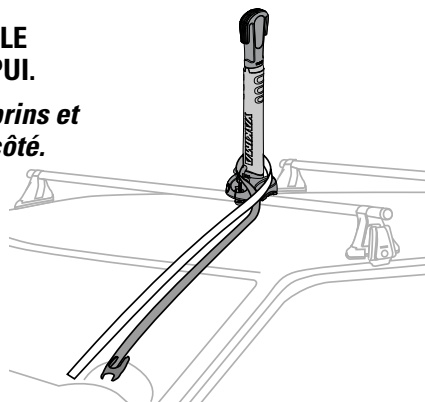

CHARGER L'EMBARCATION

- Ramener les deux brins par-dessus l'embarcation.
- Les mettre sur le côté.

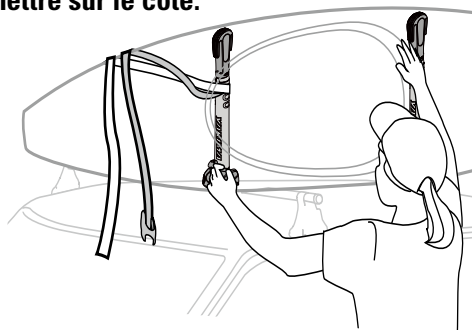

- Faire glisser la sangle pour qu'elle soit accrochée au sommet de l'appui.
- Tirer sur la sangle pour que la boucle se retrouve près du haut du kayak.

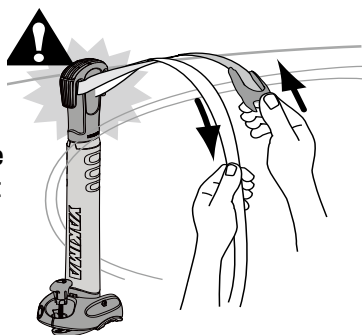

POUR PLUS DE SÛRETÉ :

- Passer la sangle vers l'intérieur sous la barre transversale.
- Passer la sangle sous l'embarcation autour de la base de l'appui.
- Passer de nouveau sous la barre et ensuite dans la boucle.

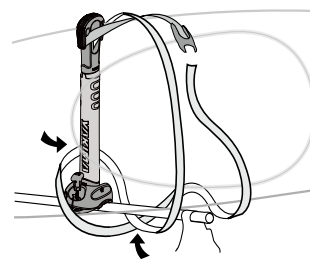

REMARQUE : les sangles doivent passer à l'intérieur des pieds. Si l'on est obligé de faire passer les sangles à l'extérieur des pieds à cause de la position des barres ou des pieds, employer les butées STRAP CAP (article Yakima n_ 8005015) pour empêcher les sangles de glisser par-dessus le bout des barres.

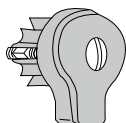

Article Yakima n_ 8005015
(vendu à part)

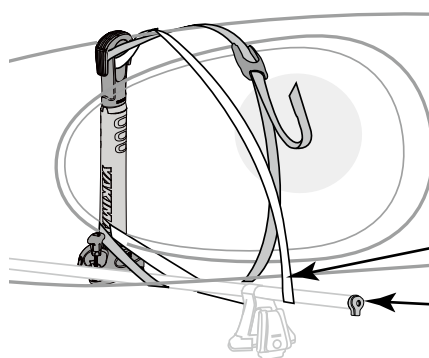

Si la sangle est à l'extérieur des pieds

Employer les butées STRAP CAP

10

RÉUNIR LES DEUX BOUTS DE LA SANGLE ET SERRER

- Enfiler le bout de la sangle dans la boucle tel qu'illustré.

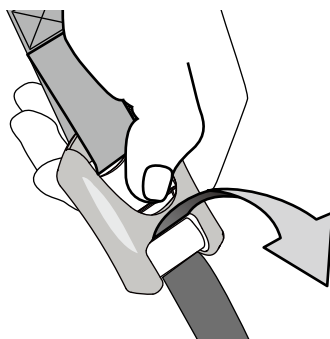

SERRER LES SANGLES :

- Pour serrer les sangles, tirer vers le bas en retenant l'autre brin.
- Attacher l'excédent.

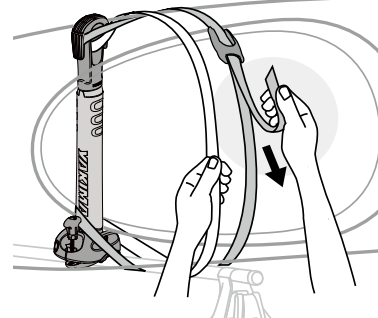

11 POSER LES SERRURES SKS EN SUIVANT LES INSTRUCTIONS QUI LES ACCOMPAGNENT

(vendues à part)

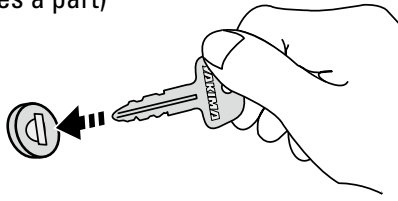

Les lignes du bouton de serrage et de la base de l'appui doivent être alignées pour pouvoir verrouiller.

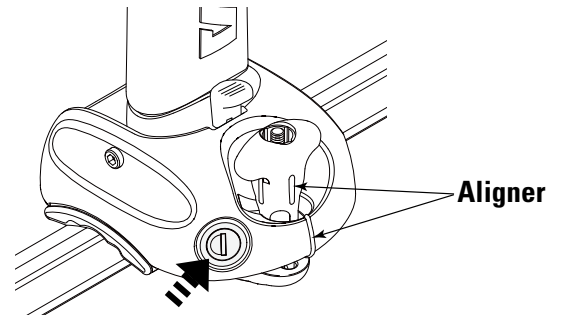

INSTALLATION DES SANGLES D'ARRIMAGE AVANT/ARRIÈRE

12 Attacher la sangle avec boucle à l'embarcation.

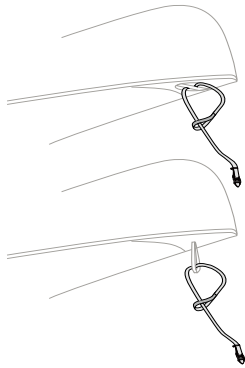

Fixer la sangle à la poignée ou à la barre de transport et bien serrer.

13 Fixer le crochet dans l'anneau de la sangle sans boucle.

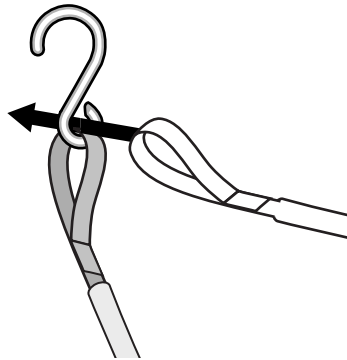

14 Accrocher la sangle à un rebord métallique du pare-chocs, à un anneau de remorquage ou dans un trou du châssis.

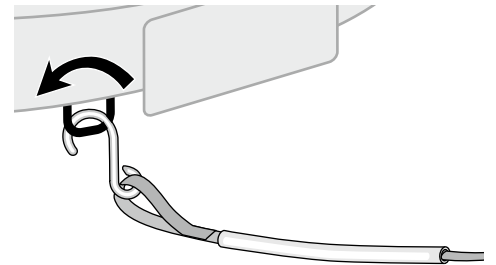

15 Faire coulisser le manchon en plastique pour protéger le véhicule au point de contact.

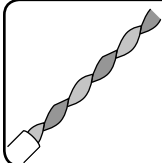

REMARQUE : si l'on donne plusieurs tours à la sangle elle vibrera moins dans le vent.

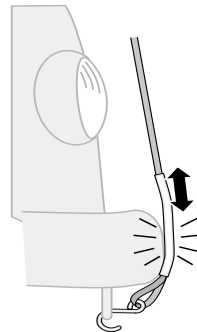

17 Régler la tension de la sangle en tirant sur le bout libre.

- Tendre également les sangles avant et arrière.
- Enrouler et attacher l'excédent des sangles.

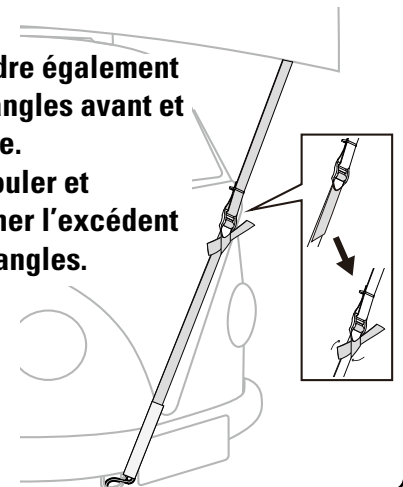

16 Enfiler le bout de la sangle sans boucle dans la boucle.

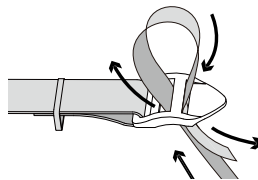

Toujours attacher le bout des charges longues à l'avant et à l'arrière du véhicule, sous peine de risquer de provoquer des dommages, des blessures ou même la mort.



Vérifier les sangles régulièrement durant le trajet et les serrer au besoin. Si une sangle est usée ou effilochée, la remplacer (consulter le dépositaire Yakima).



AVANT DE PRENDRE LA ROUTE

- Vérifier la solidité du montage en balançant l'embarcation.
- Serrer les sangles ou les boulons un peu plus s'il y a du jeu.
- Respecter tous les avertissements et toutes les limitations.

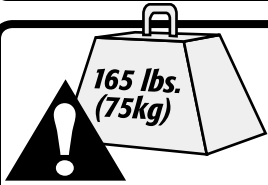

LIMITE DE CHARGEMENT

Consulter la liste de compatibilité YAKIMA ("Fit list") ou le site yakima.com pour connaître la limite de chargement. Ne pas dépasser la limite de chargement fixée pour le porte-bagages d'origine.

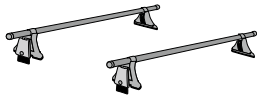

PORTE-BAGAGES



CE PRODUIT (7 lbs. / 3.2 kg)

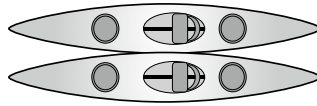

CHARGE



Ne pas dépasser 75 kg (165 lb) à moins d'indication contraire.

** Certains véhicules acceptent moins de 75 kg (165 lb)*

SI L'ON ENLÈVE LE PORTE-EMBARCATION, SUIVRE LES INSTRUCTIONS POUR LE REMETTRE EN PLACE.

Respecter les consignes de sécurité figurant dans les instructions avant chaque montage.

HAYON

Certaines charges particulièrement longues pourraient empêcher d'ouvrir complètement le hayon.

TOUJOURS OUVRIR LE HAYON AVEC PRUDENCE.

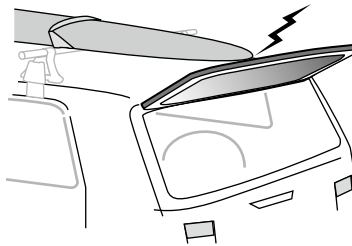

ANTENNE

Il faudra peut-être enlever l'antenne du toit si elle gêne les charges longues.



ATTENTION : S'ASSURER QUE LE MONTAGE EST SOLIDE ET CONFORME AUX INSTRUCTIONS. LES DISPOSITIFS DE FIXATION PEUVENT SE DESSERRER À LA LONGUE. LES INSPECTER AVANT CHAQUE UTILISATION ET LES RESSERRER AU BESOIN.

ENTRETIEN : lubrifier les boulons avec un lubrifiant non soluble à l'eau. Nettoyer les pièces en plastique avec un chiffon, de l'eau et un savon doux.

ENLEVER L'ACCESSOIRE AVANT DE PASSER DANS UN LAVE-AUTO AUTOMATIQUE.

RENSEIGNEMENTS TECHNIQUES OU PIÈCES DE RECHANGE, prière de contacter votre dépositaire, de consulter le site www.yakima.com ou d'appeler au (888) 925-4621, du lundi au vendredi entre 7h et 17h, heure du Pacifique.

LOVE IT TILL YOU LEAVE IT
LIFETIME
WARRANTY

Ce produit est couvert par la garantie limitée « Tant que durera notre histoire d'amour » YAKIMA. Pour se procurer une copie de cette garantie, aller en ligne à www.yakima.com ou nous envoyer un courriel à yakwarranty@yakima.com ou appeler au (888) 925-4621.

CONSERVER CES INSTRUCTIONS!

YAKIMA **BigStack**

ES

DISTANCIA MÍNIMA ENTRE LAS BARRAS TRANSVERSALES: 24 pulgadas/61 cm.

PARA PORTAEQUIPAJES DE FÁBRICA: Revise las notas de la lista de compatibilidad o visite Yakima.com para averiguar cuál es la distancia entre las barras transversales de su vehículo.

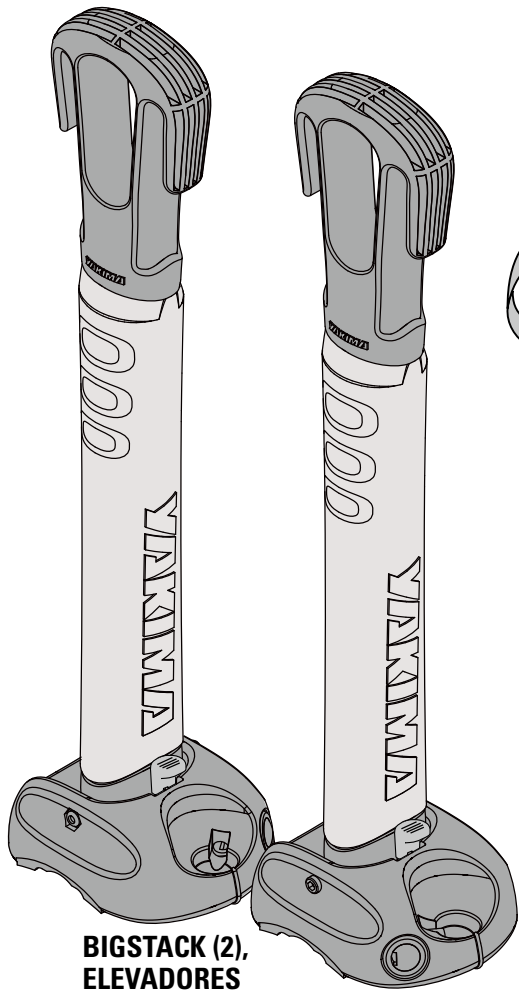

**BIGSTACK (2),
ELEVADORES**

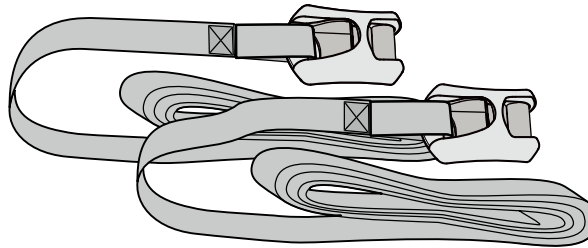

**CORREAS EXTRA
RESISTENTES (2)**

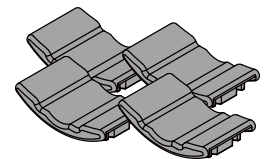

ALMOHADILLAS (4)

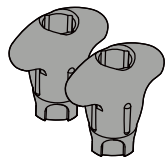

**PERILLAS DE
AJUSTE (2)**

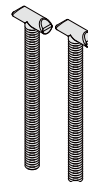

PERNOS EN T (2)

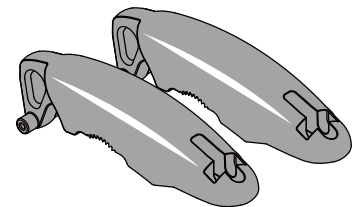

MORDAZAS (2)

AMARRE PARA PROA Y POPA

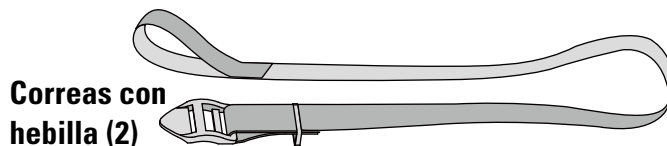

**Correas con
hebilla (2)**

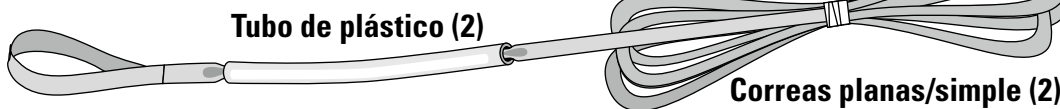

Tubo de plástico (2)

Correas planas/simple (2)

**Ganchos
metálicos (2)**



ADVERTENCIA IMPORTANTE

ADVERTENCIA IMPORTANTE ES FUNDAMENTAL QUE TODOS LOS PORTAEQUIPAJES Y ACCESORIOS YAKIMA SE INSTALEN EN EL VEHÍCULO DE MANERA CORRECTA Y FIRME. LA INSTALACIÓN INCORRECTA PODRÍA DERIVAR EN UN ACCIDENTE AUTOMOVILÍSTICO, Y PODRÍA CAUSARLES LESIONES CORPORALES SERIAS O LA MUERTE A USTED O A OTROS. USTED ES RESPONSABLE DE AJUSTAR LOS PORTAEQUIPAJES Y LOS ACCESORIOS A SU AUTO, CONTROLAR LAS INSTALACIONES ANTES DE USAR, E INSPECCIONAR EL PRODUCTO PERIÓDICAMENTE PARA COMPROBAR QUE ESTÉ AJUSTADO O VER SI HAY DESGASTE O DAÑO. POR CONSIGUIENTE, DEBE LEER Y ENTENDER TODAS LAS INSTRUCCIONES Y PRECAUCIONES SUMINISTRADAS CON EL PRODUCTO YAKIMA ANTES DE INSTALARLO O USARLO. SI NO ENTIENDE TODAS LAS INSTRUCCIONES O PRECAUCIONES, O SI NO TIENE EXPERIENCIA MECÁNICA Y NO ESTÁ TOTALMENTE FAMILIARIZADO CON LOS PROCEDIMIENTOS DE INSTALACIÓN, ES ACONSEJABLE QUE ENCARGUE LA TAREA A UN INSTALADOR PROFESIONAL.

PREPARACIÓN PARA LA INSTALACIÓN

- 1** Rote el BigStack hasta su posición vertical. En esta posición quedará sujeto.

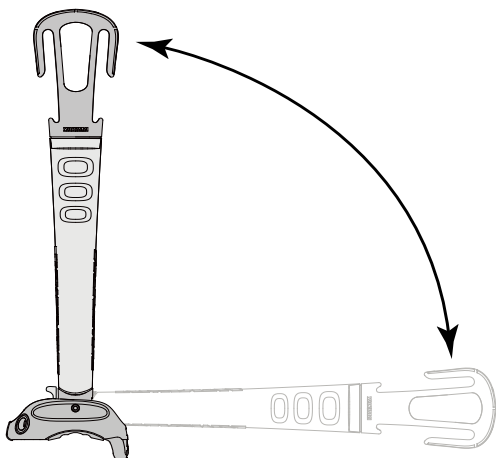

NOTA: Utilice el botón de desenganche rojo ubicado en la base cuando desee bajar el mástil.

- 2** Instale las dos almohadillas.

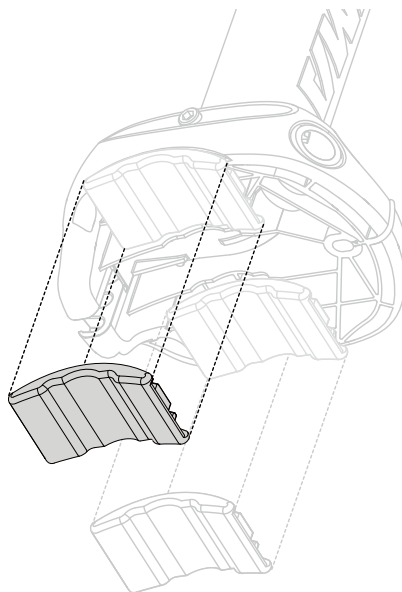

- 3** Inserte el perno en T por la base del BigStack y la perilla de ajuste.

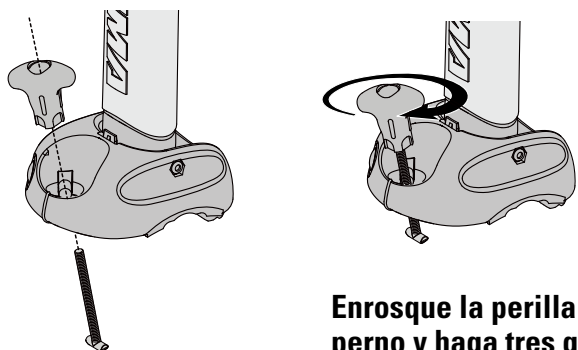

Enrosque la perilla en el perno y haga tres giros completos.

- 4** Escoja la ubicación del BigStack en la barra transversal, antes de ir al paso 5.

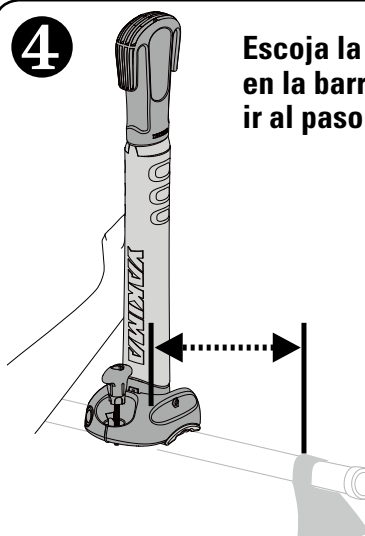

La distancia entre el BigStack y la torre debe ser igual al ancho de su kayak (o kayacs), instalados de lado.

INSTALACIÓN DEL BIGSTACK EN LAS BARRAS TRANSVERSALES

- 5** SÓLO PARA BARRAS REDONDAS

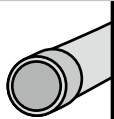

Enganche la mordaza a la base, alrededor de la barra transversal.

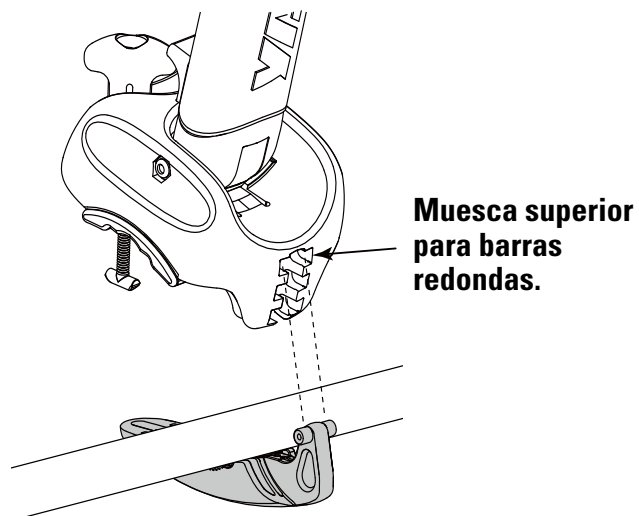

5 SÓLO PARA BARRAS CUADRADAS

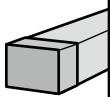

Enganche la mordaza a la base, alrededor de la barra transversal.

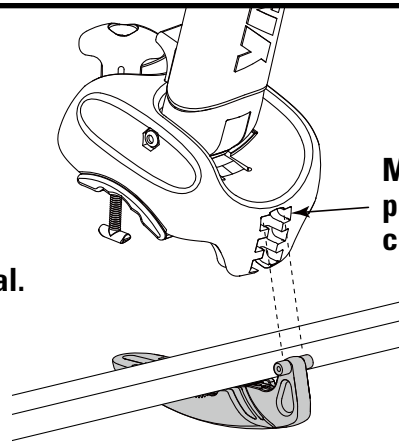

Muesca superior para barras cuadradas.

5 SÓLO PARA BARRAS DE FÁBRICA

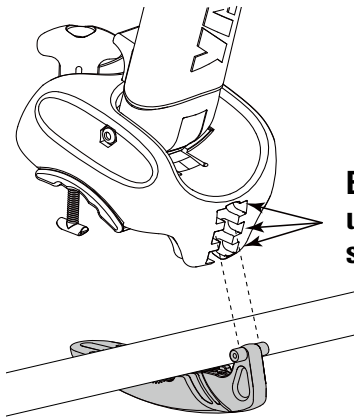
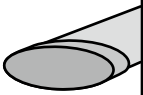

Escoja la mejor ubicación para una sujeción más segura.

6 Inserte el perno en T por la mordaza.

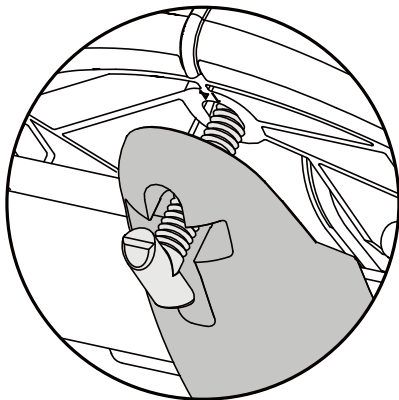

Rote el perno en T.

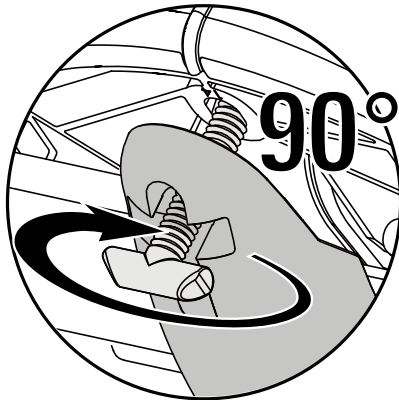

7 AHORA AJUSTE COMPLETAMENTE EL BIGSTACK CON PRESIÓN FIRME.

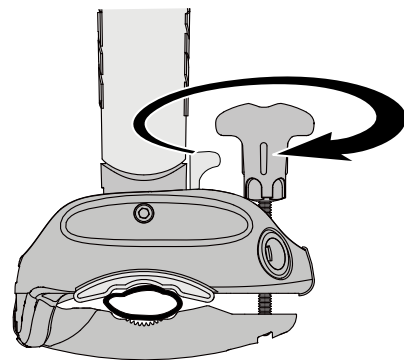

8 INSTALE EL SEGUNDO BIGSTACK

Repita los pasos 1 a 7 para instalar el segundo elevador.

Instale los elevadores de manera que las cajas de los cerrojos miren hacia el mismo lado del vehículo.

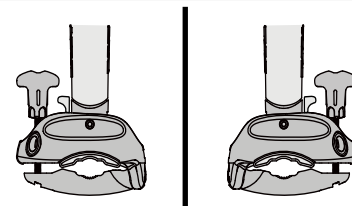

Instale los elevadores de manera que estén desalineados y se plieguen uno en el sentido del otro.

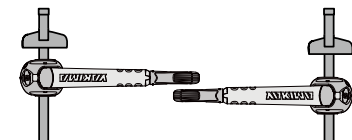



PRECAUCIÓN: Es probable que necesite volver a ubicar los BigStack para evitar el contacto con el vehículo.

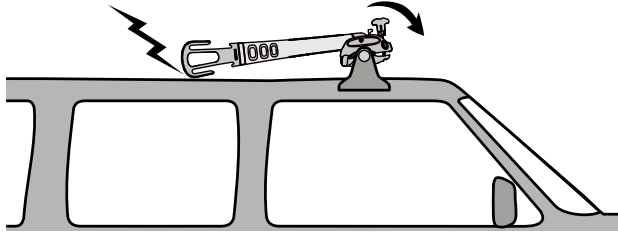

PRECAUCIÓN: Es probable que necesite desalinearse los BigStack de manera que los mástiles puedan bajarse cuando no se usan.

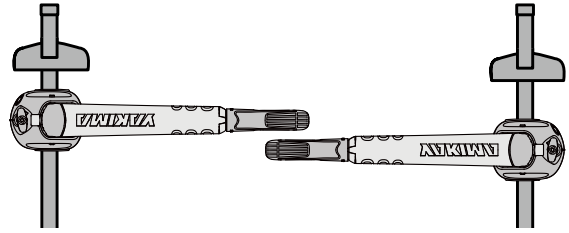

PREPÁRESE A CARGAR SU(S) BOTE(S)

NO RECOMENDABLE

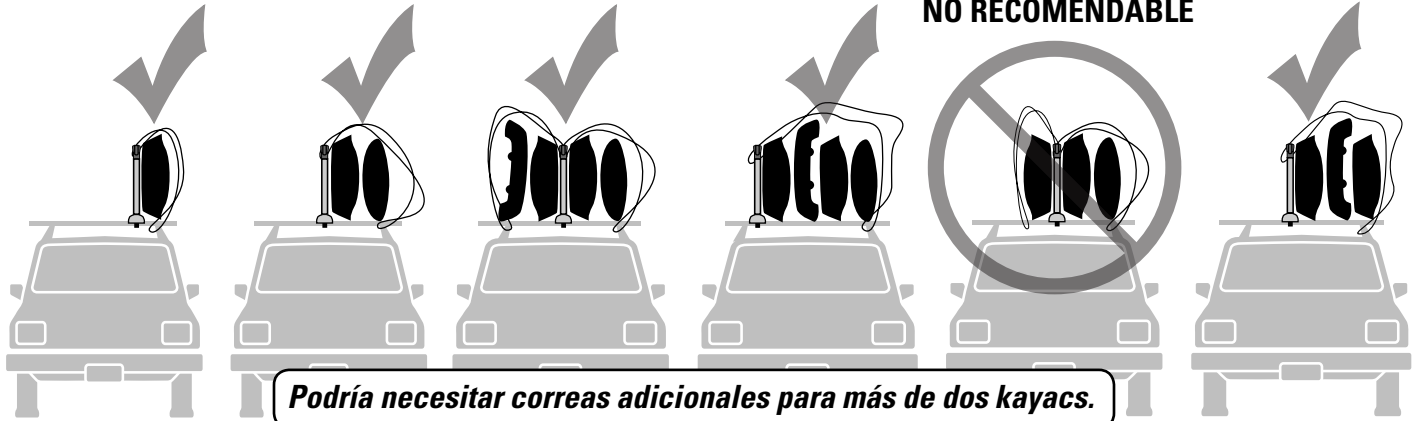

Podría necesitar correas adicionales para más de dos kayacs.

SIGA ESTAS CUATRO RECOMENDACIONES CUANDO SUJETE EL(LOS) KAYAC(S) CON LAS CORREAS:

1

La distancia del BigStack desde la torre de las barras transversales es exactamente igual al ancho del(de los) kayak(s) instalados de lado.

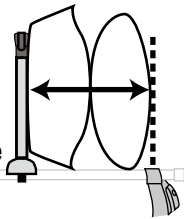

2

Pase la correa por debajo de la barra transversal, al menos una vez.

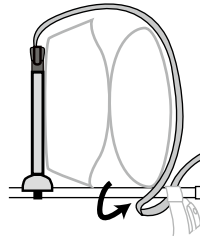

3

Pase la correa por entre los lados de la torre de la barra transversal.

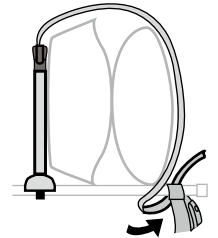

4 Siempre amarre la proa y la popa. Consulte el paso 12 para conocer el procedimiento adecuado de amarre de la proa y la popa.

9 CARGUE EL BOTE – ÁTELO CON LAS CORREAS

PARA CARGAR CON LA CORREA Y EL BIGSTACK EN POSICIÓN HORIZONTAL:

Pase la correa por el agujero.

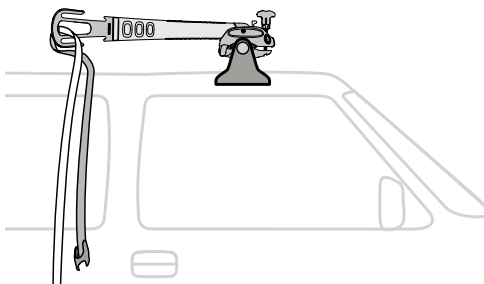

Coloque el mástil en posición vertical.

Ate el(los) bote(s) como se muestra en las páginas siguientes.

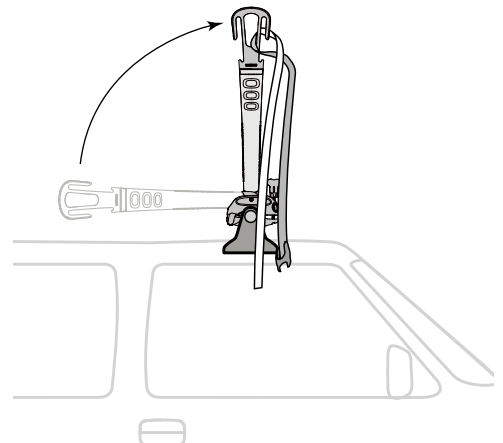

CARGUE EL BOTE – ÁTELO CON LAS CORREAS (CONTINUACIÓN)

CON LA CORREA Y EL BIGSTACK EN POSICIÓN VERTICAL:

PASE LA CORREA ALREDEDOR DEL BIGSTACK.

Cruce las correas y póngalas a un lado.

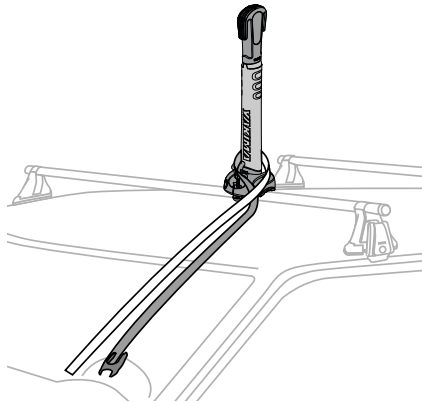

CARGUE EL BOTE.

- Pase las correas por arriba y encima del bote.
- Déjelas que cuelguen a un lado.

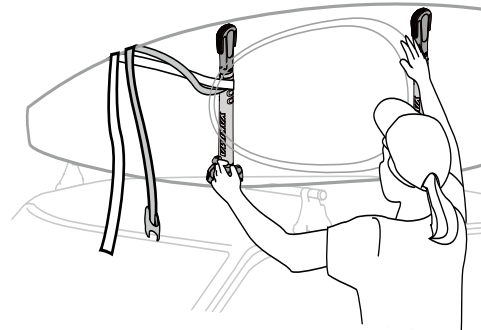

- Enganche la correa por la parte de arriba del BigStack.

- Deslice la hebilla por arriba de manera que cuelgue por el borde superior del bote.

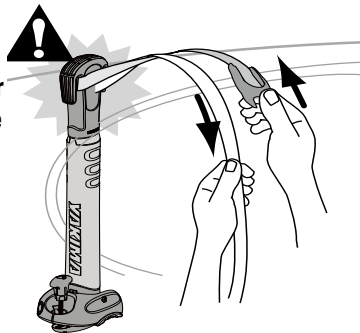

SEGURIDAD ADICIONAL:

- Pase la correa entre los lados y por debajo de la barra transversal.
- Pase la correa por debajo del bote alrededor de la base del BigStack.
- Pase la correa nuevamente por debajo de la barra transversal y sujétela a la hebilla.

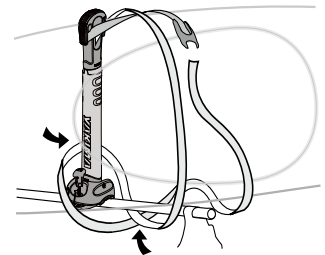

NOTA: Las correas deben estar colocadas en el espacio entre y las torres. Si deben quedar fuera de la torre debido a la posición de la torre/barra, utilice TAPONES PARA CORREAS (Pieza de Yakima No. 8005015) para evitar que se deslicen fuera de la barra.

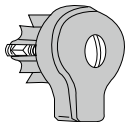

Pieza Yakima No. 8005015 (se vende por separado).

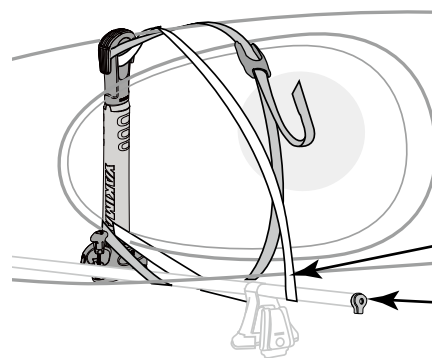

Correas fuera de la torre.

Use tapones para correas.

10

ENGANCHE Y AJUSTE

- Inserte el extremo de la correa en la hebilla como se muestra en la ilustración.

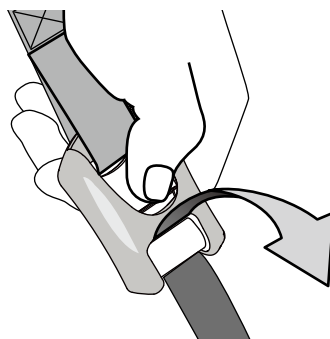

ASEGURE LAS CORREAS:

- Para asegurar la correa, sostenga y tire de ella.
- Asegure la segunda correa.

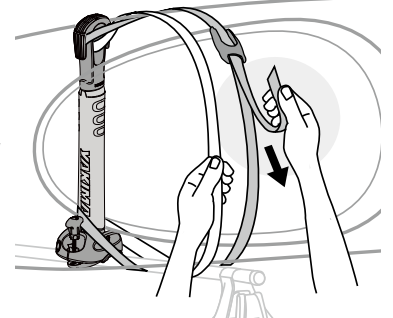

- 11** INSTALE CERROJOS SKS SEGÚN LAS INSTRUCCIONES DE LOS MISMOS (se venden por separado).

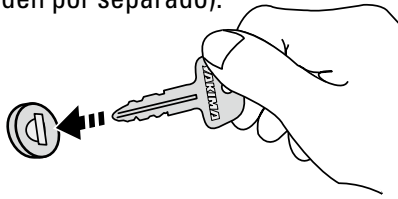

Para que cierre, las líneas en la perilla de ajuste y la base del BigStack deben estar alineadas.

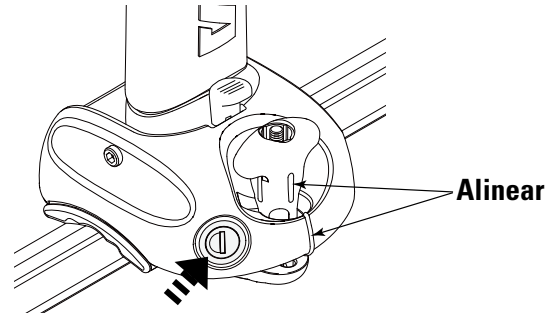

SUJECIÓN DEL AMARRE PARA PROA Y POPA

- 12** Sujete la correa con hebilla al bote.

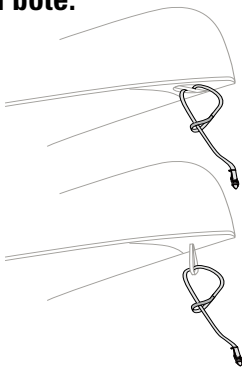

Sujete la correa al asa o a la barra de rescate y tire para que quede bien ajustado.

- 13** Sujete el gancho al bucle de la correa plana.

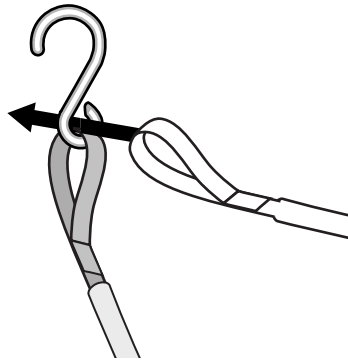

- 14** Inserte el gancho con la correa en una superficie de metal en el parachoques, en el gancho de remolque o un agujero de la carrocería.

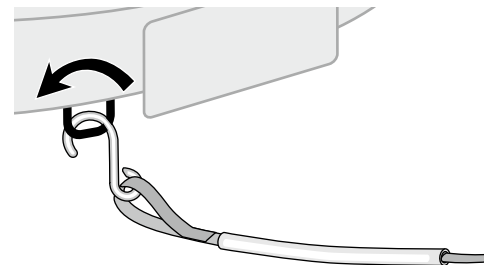

- 15** Deslice el tubo de plástico para proteger el vehículo en el punto de contacto.

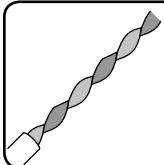

NOTA: Torcer la correa ayudará a reducir la vibración causada por el viento.

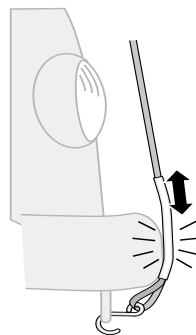

- 17** Ajuste la tensión de la correa jalando el extremo plano.

- Utilice una presión uniforme en las correas delanteras y traseras.
- Esconda y ate cualquier exceso de las correas.

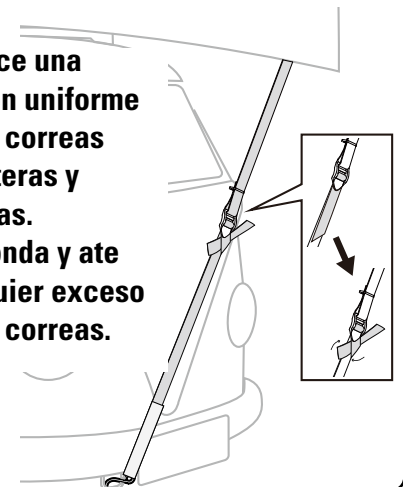

- 16** Inserte el extremo de la correa plana en la hebilla.

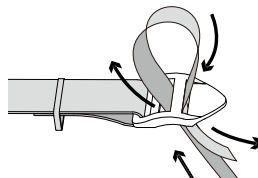

No asegurar la parte delantera y trasera de cargas largas a los extremos del vehículo puede ocasionar daños a la propiedad, lesiones o incluso la muerte.



Revise las correas periódicamente durante el viaje y asegúrelas, si es necesario. Reemplace toda correa gastada o deshilachada antes de usarla (consulte a su concesionario de Yakima).



ANTES DE SALIR DE VIAJE

- Revise el movimiento, meciendo el bote.
- Ajuste nuevamente si hay indicios de movimiento.
- Lea todas las precauciones y límites.

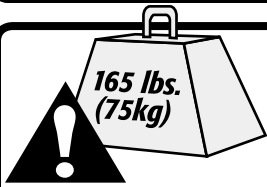

LÍMITES DE PESO

Siga la Guía de uso YAKIMA o visite yakima.com para informarse sobre el límite de peso de los rieles. No exceda el límite de peso de los rieles de su vehículo.

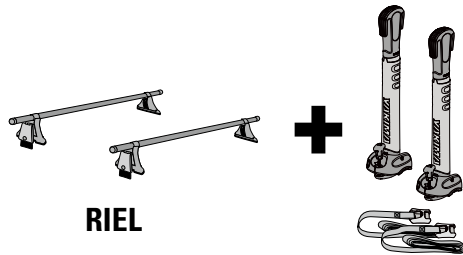

RIEL

CARGA

165 libras (75 kg) máximo, a menos que se indique lo contrario.

ESTE PRODUCTO (7 lbs. / 3.2 kg)

**[Algunos vehículos indicarán un máximo inferior a 165 libras (75 kg).]*

SI SACA SU PORTAEQUIPAJES, SIGA LAS INSTRUCCIONES PARA VOLVERLO A INSTALAR.

Antes de cada instalación, realice las revisiones de seguridad que se indican en las instrucciones de los accesorios.

PUERTA TRASERA

Algunas cargas más largas pueden impedir la apertura completa de la puerta trasera.

AL ABRIR LA PUERTA TRASERA SIEMPRE TOMA TODAS LAS PRECAUCIONES NECESARIAS.

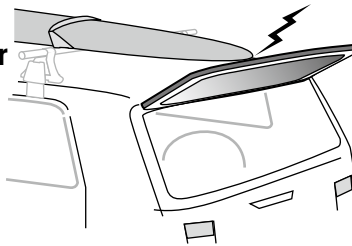

ANTENA

Es probable que necesite sacar la antena del techo, para evitar interferencia con las cargas largas.



ADVERTENCIA: CERCÍOARSE DE QUE TODO EL HERRAJE ESTÉ SUJETO SEGÚN LAS INSTRUCCIONES. EL HERRAJE DE SUJECIÓN PUEDE AFLOJARSE CON EL TIEMPO. VERIFIQUELO ANTES DE CADA USO Y AJÚSTELO, SI ES NECESARIO.

MANTENIMIENTO: Use lubricante no soluble en agua para los tornillos. Use un paño suave y humedecido en agua y detergente suave para limpiar las piezas de plástico.

RETIRE LOS ACCESORIOS ANTES DE ENTRAR A UN ESTABLECIMIENTO PARA LAVADO AUTOMÁTICO DE VEHÍCULOS.

ASISTENCIA TÉCNICA O REPUESTOS
Comuníquese con su concesionario o visite www.yakima.com; también puede llamar al (888)925-4621 de lunes a viernes, de 7:00 a.m. a 5:00 p.m., hora del Pacífico.

LOVE IT TILL YOU LEAVE IT
LIFETIME
WARRANTY

GARANTÍA LIMITADA A VIDA "MIENTRAS DURE EL ROMANCE"
Este producto está cubierto por la garantía limitada a vida "mientras dure el romance" de Yakima. Para obtener una copia de esta garantía, visítenos en www.yakima.com, envíenos un correo electrónico a yakwarranty@yakima.com o llámenos al (888) 925-4621.

CONSERVE ESTAS INSTRUCCIONES